

Recommendations of RILEM TC 176: Test methods of frost resistance of concrete

Comments should be sent to the TC Chairman: M. J. Setzer, University of Duisburg-Essen, IBPM – Institute of Building Physics and Material Science, Postfach 45117 Essen, Germany; email: mj.setzer@uni-essen.de

Remarks by the Chairman of RILEM TC 176-IDC:

I. Formal decisions:

The RILEM TC 176-IDC decided at its meetings in Bergamo (2000), Paris (2000), Essen (2001) and Helsinki (2002):

1. Two test procedures shall be published as drafts of RILEM Recommendations:
CIF-test and modified Slab test.
The CIF test extends the existing RILEM Recommendation CDF test¹ which was developed for measuring the scaling under the attack of frost and de-icing agents.
The modified Slab test relies on the Swedish Standard SS137244.
2. The tests are presented to give a basis for gaining experience.
3. The descriptions shall be based on proposals already distributed to the Committee.
4. Responsible authors are for CIF-Test M.J. Setzer and for Slab-Test Per-Erik Petersson and Luping Tang.
5. Two inter-laboratory-tests have been performed by RILEM TC 176-IDC in 2000 – one for CIF and one for modified Slab test, each comprising three concretes. The results have been evaluated strictly basing on ISO 5725 by Dr. Auberg and Mrs. Kasperek for CIF and by Dr. Luping Tang for modified Slab test. The results have been cross-checked by the two groups. The RILEM TC 176-IDC decided to use these precision data for the drafts.
6. The deadline for any comments to the drafts ended April 30, 2002.
7. The final recommendation shall be published. (Helsinki 2002)
8. The internal damage is a yes/no decision. For the internal damage found by ultrasonic transit time in CIF test it has been agreed upon that a damage criterion of $R_{in}=0.8$ (80%) can be given where a damaged concrete can be distinguished from an undamaged ($R_{in}=1.0$) with sufficient statistical precision ($3*s_R$). The test result is assessed by the number of cycles which are passed until damage criterion.

II. Comments by the Chairman:

1. It must be taken into account that the results and especially the level of damage is different in both tests – CIF test and modified slab test. Therefore, it is not appropriate to compare the simple number even if similar physical parameters or naming are used such as transit time, dynamic elastic modulus and relative length change.
2. Based on the inter-laboratory-test, the measured damage can be up to a factor of 3 higher in CIF than in modified Slab test.
3. The damage levels criterion as defined herein (CIF) by the transgression below the relative dynamic modulus of 0.8 marks the value where a damaged concrete can be distinguished with sufficient statistical certainty from an undamaged. Therefore, it has to be distinguished from the acceptance criterion.
4. The acceptance criterion is the number of cycles a concrete must survive before the damage criterion is passed.
5. The RILEM TC 176-IDC is not prepared at this time to propose acceptance criteria. Acceptance criteria are in the responsibility of contractors of committees or standardization. For this, additional data which link the test results with performance under practical conditions are necessary (such conditions can vary considerably based on local and regional climatic conditions).

MEMBERSHIP: Chairman: M. J. Setzer; Secretary: D. J. Janssen; Voting Members: R. Auberg (Germany); D. H. Bager (Denmark); G. Gudmundsson (Iceland); S. Jacobsen (Norway); H. Kukko (Finland); T. Miura (Japan); H. Mihashi (Japan); V. Penttala (Finland); P.-E. Petersson (Sweden); E. Schulson (USA); J. Stark (Germany); L. Tang (Sweden); P. Ursella (Italy)

CIF-Test - Capillary Suction, Internal damage and Freeze-thaw Test Reference method and alternative methods A and B

Responsible author M. J. Setzer

Editorial Committee:

IBPM*: P. Heine, S. Kasperek, S. Palecki; WISSBAU**: R. Auberg; FIZ⁺: V. Feldrappe, E. Siebel

* Institut für Bauphysik und Materialwissenschaft, Universität Duisburg-Essen

** WISSBAU Beratende Ingenieurgesellschaft mbH, Essen

⁺ Forschungsinstitut der Zementindustrie, Düsseldorf

1. SCOPE

Adequate resistance of concrete to freeze-thaw attack should be verified by laboratory tests such as the CIF Test. CIF means “*Capillary suction, Internal damage and Freeze-thaw test*”. The CIF test is based upon the RILEM Recommendation of the CDF-test (*Capillary Suction, De-icing agent and Freeze-thaw Test*), where precision data for scaling have been determined, and complements this test.

(1) CDF Test - Test method for the freeze-thaw resistance of concrete - tests with sodium chloride solution (CDF). RILEM Recommendation TC117-FDC: Freeze-thaw and de-icing resistance of concrete. Materials and Structures Vol. 29 (1996) 523-528

During the CIF test, the degree of saturation of a concrete specimen is increased reproducibly, first by isothermal capillary suction and then by repetition of a well-defined freeze-thaw cycle (frost-suction). The CIF-Test enables the measurement of the moisture uptake as well as the internal damage by a number of freeze-thaw cycles with uniaxial heat and liquid flux with a defined test liquid, normally demineralized water. The moisture uptake and associated degree of water saturation is a substantial parameter in order to determine the frost resistance. The test method is combined with the measurement of the surface scaling.

It is recommended to determine the moisture uptake and the internal damage within the CDF-Test according to the RILEM Recommendation (3% sodium chloride solution) - modified CDF-Test - as well. In this case usually the scaling is dominant.

The procedure can be applied for testing all types of concretes (cast-in-place concrete, production items such as paving blocks and curbs, and pre-cast members), as well as concrete mix constituents and individual concrete mixtures. The test requires specimens that are essentially homogeneous. Multi-layered specimens or severely segregated concrete need special investigation by experts.

2. STANDARDS

- /1/ prEN-ISO 2736/2: Testing hardened concrete-test specimens. Part 2: Making and curing of test specimens.
- /2/ E ISO/DIS 8047 (1982-12): Concrete, hardened; determination of ultrasonic pulse velocity,
- /3/ ISO 5725/1 to 6-1990: Accuracy (trueness and precision) of measurement methods and results.
- /4/ VDI/VDE 3522: Time performance of contact thermometers (Zeitverhalten von Berührungsthermometern). June 1987.
- /5/ CDF Test - Test method for the freeze-thaw resistance of concrete - tests with sodium chloride solution (CDF). RILEM Recommendation TC117-FDC: Freeze-thaw and de-icing resistance of concrete. Materials and Structures Vol. 29 (1996) 523-528.

3. DEFINITIONS

- a) The *freeze-thaw resistance* is the resistance against alternating freezing and thawing in the presence of demineralized water as the test liquid.
- b) The *test liquid* is the liquid which is taken up during the test procedure (see Section 4 c).
- c) *Scaling* is the loss of material from the surface of concrete due to freeze-thaw or freeze-thaw de-icing agent attack.
- d) *Internal damage* is the deterioration of the internal structure of concrete (even without visible external damage) which leads to a change in the concrete properties (e.g. a reduction of the dynamic modulus of elasticity).
- e) The *reference point* is the physical measuring point at which the temperature cycle is controlled.
- f) The *reference temperature* is the temperature measured at the reference point.
- g) The *test surface* is the surface of the test specimen over which the temperature change and test liquid attack the specimen during the test procedure.
- h) The *ultrasonic transit path* is the length over which the ultrasonic transit time is measured.

- i) The *transit time* is the time required by an ultrasonic pulse wave to cover the ultrasonic transit path between the transmitter and receiver.
- j) The *ultrasonic transit axis* is the hypothetical shortest distance between the centers of the coupling surfaces of the transmitter and receiver transducers.
- k) The test liquid is used as the *coupling medium*. It enables a reproduceable signal transfer between the transducers and the specimen.

4. EQUIPMENT

- a) *Climate chamber*: With a temperature of $20 \pm 2^\circ\text{C}$ and a relative humidity of $65 \pm 5 \%$.
- b) *Lateral sealing*: Aluminium foil with butyl rubber (reference) or epoxy resin (alternative). Both must be durable at temperatures of -20°C . They must not be brittle at the minimum temperature. An adequate primer has to be applied.
- c) *Test liquid*:
 Freeze-thaw test: Demineralized water
 Modified freeze-thaw and de-icing agent test of CDF-Test: standard de-icing agent solution, 97% by weight of demineralized or distilled water and 3% by weight of NaCl.
- d) *Test containers* (Figs. 1 and 2): The test containers are made of stainless steel. The thickness of the air layer between the vertical side of the specimen and the test container is restricted to $30 \pm 20 \text{ mm}$.^{2,3} A spacer of $5 \pm 0.1 \text{ mm}$ and a lid are required.

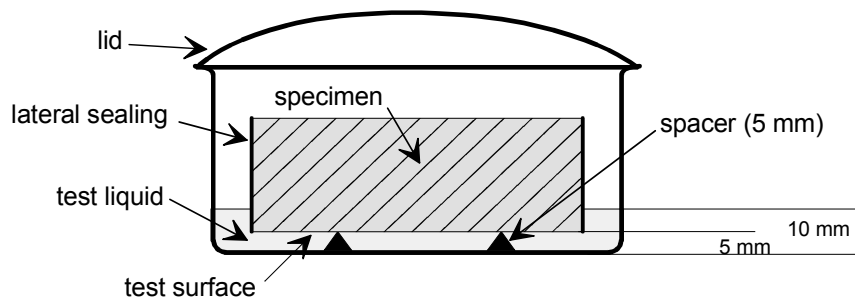

Fig. 1: Capillary suction

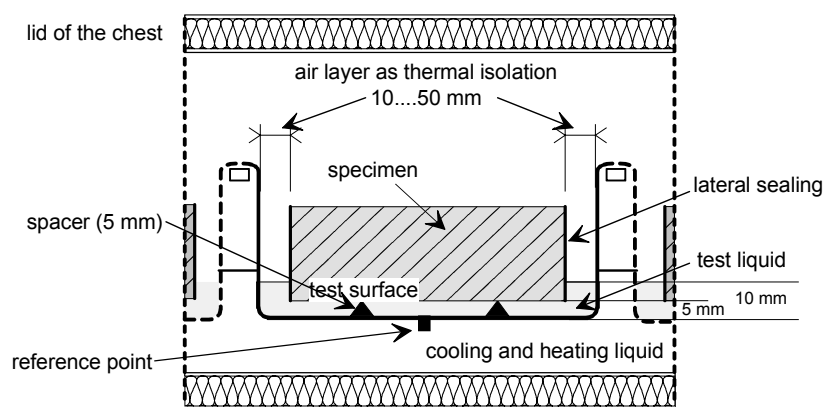

Fig. 2: Test container with specimen in a cooling and heating liquid

(2) The air layer between the vertical side of the specimen and the test container acts as thermal insulation.

(3) Different specimen sizes can be accommodated by a series of modular containers meeting the vertical air layer thickness requirement.

- e) *Temperature controlled chest* (Fig. 3): A chest with a liquid cooling and heating bath is used. The temperature of the cooling and heating bath is controlled by an appropriate device. The heating and cooling capacity and the control unit must be capable of maintaining the temperature regime at the reference point according to the temperature cycle (Fig. 4).

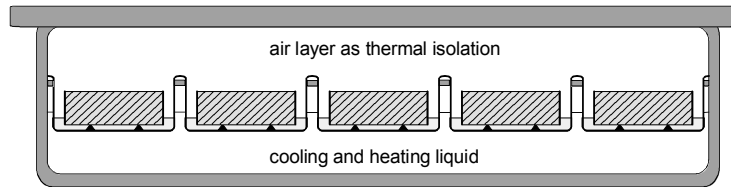

Fig. 3: Temperature controlled chest

The chest must be equipped with supports for the test containers above the tempering bath to ensure an immersion depth of the bottom of the test containers of 15 ± 3 mm. During the freeze-thaw cycles the upper space of the chest containing the specimens must be separated from the cooling bath either by the test containers or by other lids.⁴

A test container placed at an appropriate position in the bath (usually in the center) is used to monitor and control the reference temperature. The reference temperature is measured in the tempering bath at the bottom of a test container. The reference point is positioned in good thermal contact at the center of the container base.

A temperature gauge with an accuracy of ± 0.05 K at 0°C is used for the measurement. The temperature gauge must be in the form of a rectangular container with dimensions $50 \times 6 \times 6$ mm ± 0.2 mm. The temperature gauge is fixed so that the long side lies in the direction of the flow. The time constant ($t_{-90\%}$) of the probe (without securing device), determined according to VDI/VDE 3522 in a flowing water bath, must be 6.3 s ± 0.8 s. The minimum temperature of -20°C is used for calibration.

The tempering bath must guarantee a freeze-thaw cycle according to the temperature cycle in Fig. 4.

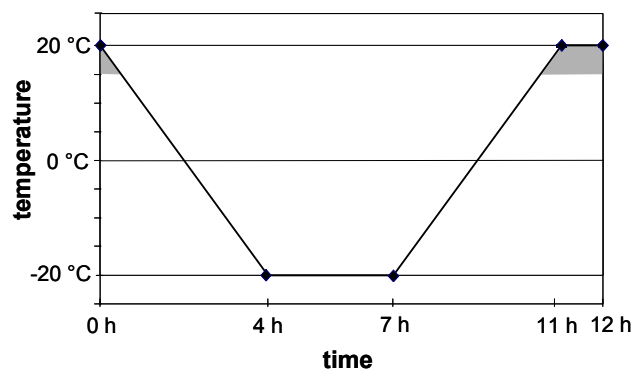

Fig. 4: Control temperature cycle

A 12 h freeze-thaw cycle is applied (Fig. 4). Starting at $+20^\circ\text{C}$ the temperature is lowered in 4 h with a constant cooling rate of 10 K/h. It is kept constant for 3 h at -20°C and increased in 4 h with a constant heating rate of 10 K/h. It is kept constant for 1 h at $+20^\circ\text{C}$. The temperature cycle is monitored at the reference point. The deviation of

(4) When conducting the test in a cryogenic bath, no cover of the test containers is required, since the chest lid will provide a sufficient evaporation barrier, while the container wall will serve as a cold trap.

temperature measured at the reference point cannot be more than ± 0.5 K at the minimum temperature and not more than ± 1 K at other temperatures. A constant time shift between the test containers is acceptable. The damage parameters are measured while the temperature is above 15°C (shaded area in Fig. 4).

- f) *Unit for adjusting liquid level:* With the device a level of the test liquid within the test container is established to 10 ± 1 mm, for example a suction device (Fig. 5) can be used which consists of a capillary tube with a spacer of 10 ± 1 mm that is connected to a water jet pump to remove the excessive liquid in the test containers.

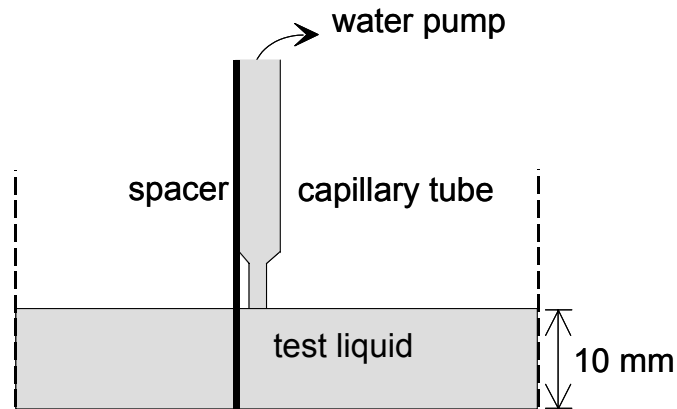

Fig. 5: Suction device

- g) *Ultrasonic bath* (Fig. 6): The size of the ultrasonic bath must be sufficiently large. The test containers have to fit in the ultrasonic bath without mechanical contact in the area between the water and test container. Additionally, a minimum distance between the test container and the bottom of the bath of 15 mm must be ensured. The bath must provide the following power data: ERS power 250 W; HF peak power 450 W under double half-wave operation; frequency 35 kHz.

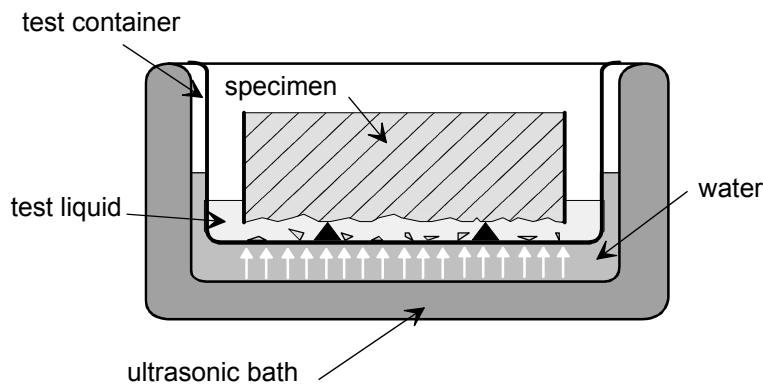

Fig. 6: Ultrasonic bath

- h) *Equipment for measuring the ultrasonic transit time:* The transit time is measured by using conventional commercially available ultrasonic equipment, which is suitable for determining the transit times of longitudinal waves in porous building materials according to E ISO/DIS 8047. The transducers should operate in a frequency range between 50 and 150 kHz.

- i) *Test container for ultrasonic transit time measurement:* A rectangular container (made e.g. of PMMA) is used for the transit time measurement. The transducers are mounted in recesses in two opposite faces of the container so that the transit axis lies parallel to and at a distance of 35 mm from the test surface (Fig. 8). The dimensions of the test container must enable calibration according to 7.4.2.
- j) *Calibration test specimen:* A calibration test specimen is used for calibration of the ultrasonic transit time measurement. The dimensions are 150 x 110 x 70 mm \pm 0.1 mm. Its calibrated ultrasonic transit times must be given.
- k) *Particle collector:* A plate (1 mm stainless steel) with handles collects the scaled particles of the specimens during measurement of liquid uptake and internal damage. The dimensions of the particle collector must be larger than the test surface of the specimen to ensure that all scaled material can be collected. The folding of the edges of the plate must be 10 mm \pm 2 mm high.
- l) *Drying cabin:* A drying cabin with a temperature of (110 \pm 5) $^{\circ}$ C is used.
- m) *Paper filter:* Paper filters are used for collecting scaled material.
- n) *Balance:* With an accuracy of at least \pm 0.01 g.
- o) *Balance:* With an accuracy of at least \pm 0.1 g.
- p) *Vernier calipers:* With an accuracy of at least \pm 0.1 mm.
- q) *PTFE plates:* Standard moulds 150 x 150 x 150 mm with additional PTFE plates 150 x 150 x 2 mm (e.g. Teflon) are used.

5. TEST SPECIMENS

5.1 Requirements for size and quantity of specimens

For one series \geq 5 specimens are used and the total test surface area must be \geq 0.08 m². A minimum number of 5 specimens enables a statistical evaluation and finding possible outliers.

The height of any specimen must be 70 mm \pm 2 mm. “Note: For deviations of height see Section 7.4.5.”

5.1.1 Standard specimens

5.1.1.1 Dimensions

The dimensions of the standard test specimens are 150 x 110 x 70 mm (\pm 2 mm).

5.1.1.2 Production of specimens for testing concrete mixes or concrete constituents in a mix

For testing concrete mixes or concrete constituents in a mix, the test specimens are cast and compacted on a vibrating table in 150 mm cube moulds according to prEN-ISO 2736/2. A vertical PTFE plate is centered in the mould, which separates the mould into two halves. The PTFE plate must not be treated with any demoulding agent. The concrete surface at the PTFE plate is the test surface. Alternatively or for a larger aggregate size one PTFE disk can be placed at each side. The maximum aggregate size must not be larger than a third of the smallest ultrasonic transit path.

After 24 \pm 2 hours of curing the specimens are removed from the mould and stored for 6 days (until the age of 7 days) in tap water at 20 \pm 2 $^{\circ}$ C. If strength development of the specimens is slow, the curing period in the mould can be increased. The storage time in tap water is then decreased by the same amount.

After storage under water, the specimens are cut along the rough upper side to the width of 110 mm. In the case of lateral PTFE plates, an additional center cut is made, according to Fig. 7. The drying storage follows after this treatment.

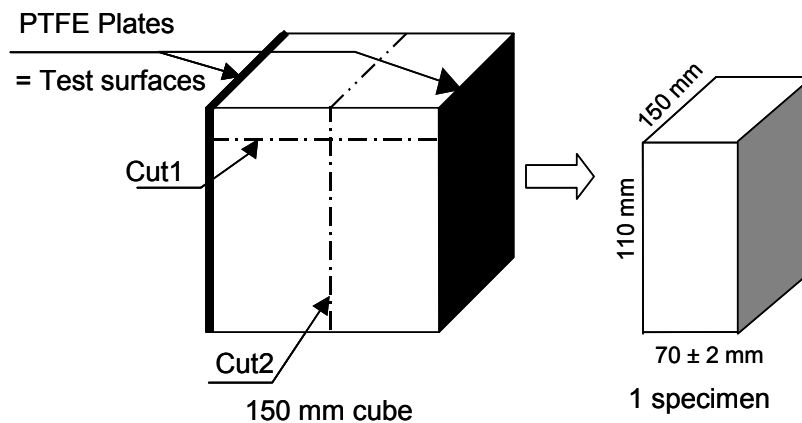

Fig.7: Sawing of test specimens in case of lateral plates

5.1.2 Deviant specimens compared to standard specimens

In case of testing deviant specimens to the standard specimens this must be mentioned in the report. The smallest dimension of the test surface must not be less than 90 mm, and irregularly-shaped specimens should be large enough to fit a 90-mm diameter circle on the test surface. The length/height ratio must not be greater than three.

“Note: For deviations of height see Section 7.4.5.”

5.1.2.1 Test specimens for testing the surface of concrete structures

The test surface should correspond to the surface of the real structure exposed to weathering. The test surface should be plane and can be of any kind.

5.1.2.2 Test specimens for testing precast concrete elements

Small precast concrete elements, such as concrete blocks and flags, can be tested directly, independent of their form. If the dimension exceeds 250 mm, the element should be cut. The test surface is the weathered surface of the element and should be plane.

6. TEST PROCEDURE

The test procedure consists of three steps: the dry storage, the pre-saturation by capillary suction and the freeze-thaw cycles. The test procedure starts immediately after the curing period. In the case of test specimens cast following Section 5.1, this happens at the age of 7 days.

6.1 Dry-storage

The concrete specimens are stored in a climate chamber (20°C/65% RH) for surface drying for 21 days. The specimens are to be placed on their sides and at least 50 mm apart so that the test surfaces are free of obstruction. The mass of each specimen has to be monitored.

6.2 Pre-saturation

6.2.1 Preparation of specimens and sealing

The specimens must be sealed on their lateral surfaces. The specimens must be clean and dry particularly on their lateral sides. Before and after the specimens are sealed they have to be weighed with an accuracy of ± 0.1 g in order to measure the reference mass of the samples without lateral sealing for the determination of the moisture uptake. Before sealing the lateral surfaces they must be treated with an appropriate primer. One of the two following methods for sealing must be applied:

a) Sealing by aluminium foil with butyl rubber (reference)

At the earliest of 3 days before the start of pre-saturation a piece of aluminium foil with butyl rubber is glued tightly on the lateral surfaces with an overlap of 20 mm. A durable interconnection must be ensured.

b) Sealing with epoxy resin (alternative)

In the range of 4 to 2 days before the start of the pre-saturation a solvent free epoxy resin is laid on the lateral surfaces, so that a sufficient hardening is ensured.

6.2.2 Pre-saturation of test liquid by capillary suction

Following dry storage the specimens are placed in the test containers on the 5 mm high spacers with the test surface on the bottom. Subsequently, the test liquid is added into the container to a height of 10 ± 1 mm without wetting the specimen's top. During the capillary suction the test container must be closed with the lid. During capillary suction it must be ensured that no condensed water drops onto the specimen.

The capillary suction period lasts 7 days at a temperature of 20 ± 2 °C. During capillary suction the liquid level should be checked in regular intervals. The mass increase of the specimens should be measured every 2 to 3 days.

6.3 Freeze-thaw testing

The freeze-thaw testing is a cyclic attack. The specimens are exposed to a freeze-thaw cycle in a temperature controlled chest according to Section 4. Before starting the freeze-thaw cycles, loosely adhering particles and dirt must be removed from the test surfaces of the specimens by treatment in an ultrasonic bath as described in Section 7.2. The material removed is discarded.

7. MEASUREMENTS

7.1 Sequence of measurement with respect to scaling, moisture uptake and internal damage

Measurements are performed at the start of the freeze-thaw test (0 freeze-thaw cycles) and after every 4th or at least every 6th freeze-thaw cycle and, in addition at the agreed criterion.

The following sequence of the measurement is imperative:

1. surface scaling
2. moisture uptake
3. internal damage (ultrasonic transit time as reference method or fundamental transverse frequencies or length change as alternative methods)

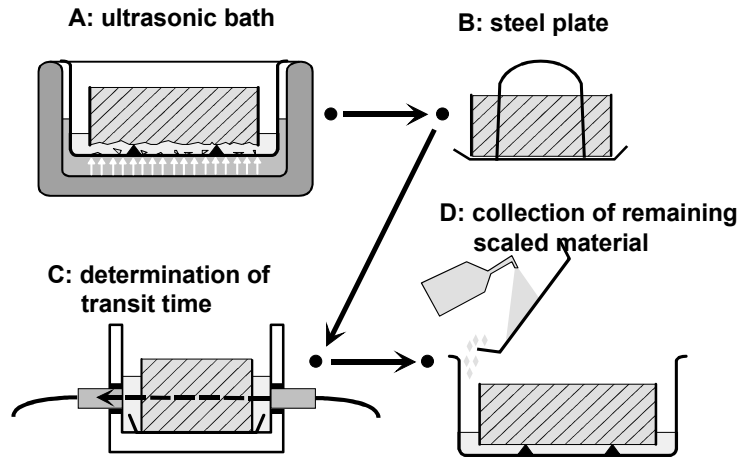

Fig. 8: Specimen handling (Reference method)

After determining surface scaling, the test specimen is laid on the steel plate according to Section 4 k) to collect additional scaled material during the following treatment. The material collected on the steel plate must be returned to the test container. It will be considered at the next measurement of scaling. If the measurement sequence is interrupted, the specimen must be positioned in the test container with the test liquid to prevent drying.

7.2 Determination of surface scaling

7.2.1 Procedure

The test container is dipped into the contact liquid of an ultrasonic bath and subjected to ultrasonic cleaning for 3 minutes, in order to remove loosely adhering scaled material from the test surface at every measurement interval.

The solution containing the scaled material is filtered. The paper filter is subsequently dried at $110 \pm 5 \text{ }^\circ\text{C}$ for 24 h and cooled for 1 h ($\pm 5 \text{ min}$) at $20 \pm 2 \text{ }^\circ\text{C}$ and $60 \pm 10 \text{ R.H.}$ The mass of the filter containing the dried scaled material μ_b is determined to 0.01 g precision. The mass of the empty filter μ_f is determined prior to filtering with the same precision.

The mass of the scaled material μ_s is then: $\mu_s = \mu_b - \mu_f$.

7.2.2 Evaluation of scaling

The total amount of scaled material m_n related to the test surface after the n th cycle is to be calculated for each measuring interval and each specimen:

$$m_n = \frac{\sum \mu_s}{A} \quad (1)$$

m_n is the total mass of scaled material related to the test surface after each measuring interval, in g/m^2

μ_s is the mass of scaled material at each measuring interval, in g with an accuracy of 0.01 g. The sum is taken over all measurements until the n th cycle.

A is the area of the test surface, in m^2 . It is calculated on the basis of the linear dimensions. It is taken as the average of at least two measurements determined to the nearest 0.1 mm.

The mean value and the standard deviation of the scaled material must be determined. The result must be checked for outliers.

7.3 Measurement of moisture uptake

7.3.1 Procedure

After removing the scaled material from the test surface the specimens are placed vertically on an absorbent surface (laboratory towel) to permit the run off of water from the test surface. The lateral and upper sides of the specimens have to be dried smoothly with a laboratory towel. In order to avoid loss of scaled material, the balance is zeroed with a steel plate on it, and the dried specimen is placed on the steel plate for weighing. The mass of each specimen is then measured with a precision of ± 0.1 g.

7.3.2 Evaluation of moisture uptake

The relative increase in mass of each specimen Δw_n after the n th cycle is calculated by:

$$\Delta w_n = \frac{w_n - w_1 + \sum \mu_s}{w_0} * 100 \quad (2)$$

Δw_n is the moisture uptake in mass of each specimen after the n th cycle, in M-%

μ_s is the mass of total scaled material at each measuring interval, in g with an accuracy of 0.01 g.

The sum is taken over all measurements until the n th cycle.

w_0 is the reference mass of the each specimen without sealing mass after pre-storage, in g.

w_1 is the mass of each specimen including sealing mass before re-saturation starts, in g.

w_n is the mass of each specimen at each measuring interval, in g.

The mean value and the standard deviation of the mass increase must be determined. The result must be checked for outliers.

7.4 Internal damage - Reference method - ultrasonic transit time

7.4.1 Experimental test arrangement

For measurement of the transit time a container according to Section 4 i) is applied. The coupling medium is the applied test liquid. The temperature of the coupling medium and the test specimen must be 20 ± 5 °C.

The ultrasonic transit time is measured with ultrasonic equipment according to Section 4 h). For each specimen the transit time is measured along two perpendicular transit axes 35 mm from the test surface. The container is filled with the test liquid to a level of 10 mm above the transducers, but not above the top of the specimen. The upper surface of the specimens must be kept dry.

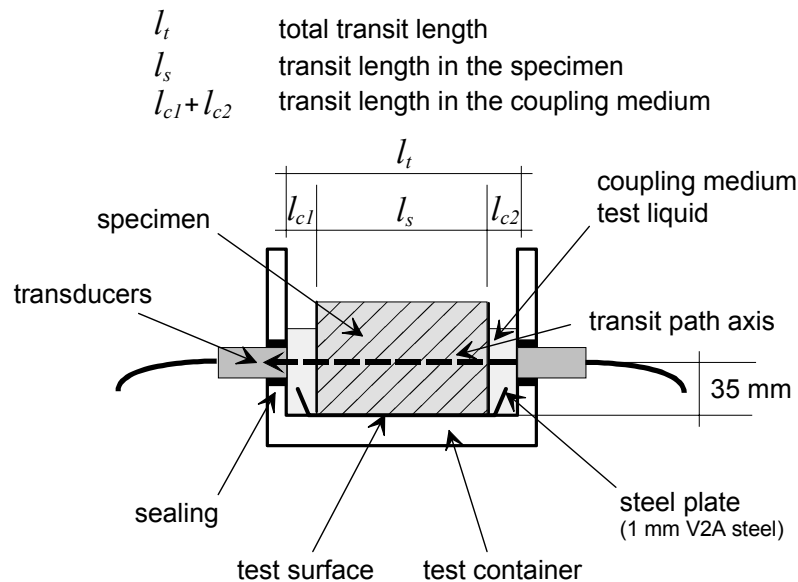

Fig. 9: Test equipment for measuring the ultrasonic transit time

7.4.2 Calibration

The test arrangement must be calibrated before starting each measuring interval:

1. Calibration of the ultrasonic device with help of the calibration specimen

The ultrasonic device is calibrated by pressing the transducers onto the surface of the calibration specimen while using an adequate coupling medium. The ultrasonic transit time is adjusted to the marked declaration of the calibration specimen.

2. Adjusting the transit time in the coupling medium

The calibration specimen is placed in the container according to Fig. 9. Subsequently, the transducers are shifted so that the declared transit time of the calibration specimen plus $10 \mu\text{s}$ is reached. Therewith the transducer distance l_t is fixed according to the calibration specimen dimension plus 15 mm.

7.4.3 Procedure

The test specimen is placed onto the steel plate in the test container for measuring the ultrasonic transit time as shown in Fig. 9. The ultrasonic transit axes marked on the specimens during the first measurement must be used for all subsequent investigations. In the case of rectangular specimens, the coupling point must be centered between the edges of the specimen. Before capillary suction commences, the specimen length which is to be crossed by the ultrasonic waves is measured to an accuracy of $\pm 0.1 \text{ mm}$. The sealing material on the sides of the specimen is excluded from this length. Before commencing the freeze-thaw cycles, the transit time is determined to an accuracy of $\pm 0.1 \mu\text{s}$. The time period in which the test surface is in contact with air should be kept as short as possible. Moistening of the upper specimen surface must be avoided. During testing, care should be taken that air bubbles do not adhere to the transducers and the sides of the specimens. The sealing material should be securely attached to the sides of the specimens.

7.4.4 Evaluation of the internal damage

The transit time in the coupling medium t_c is calculated from the transit length in the coupling medium l_c and the velocity of the ultrasonic signal in the coupling medium v_c . The transit length in the coupling medium l_c is determined by the difference between the distance of the transducers and the dimension of the test specimen l_s for each transit length with a precision of ± 0.1 mm (Fig. 9).

$$t_c = \frac{l_c}{v_c} \quad (3)$$

t_c is the transit time in the coupling medium, in ms

l_c is the transit length $l_{c1} + l_{c2}$ in the coupling medium, in mm

v_c is the velocity of the ultrasonic signal in the coupling medium, which can be assumed to 1490 m/s for water between $20\text{ }^\circ\text{C} \pm 5\text{ }^\circ\text{C}$.

The change of relative transit time τ_n after n freeze-thaw cycles is calculated separately for each specimen and transit axis by⁵:

$$\tau_n = \frac{t_{cs} - t_c}{t_n - t_c} \quad (4)$$

τ_n is the relative transit time

t_{cs} is the total transit time at the end of capillary suction (cs), in ms before the first freeze thaw cycle.

t_n is the total transit time after n freeze-thaw cycles (ftc), in ms

Instead of change of relative transit time it is convenient to express internal damage as dynamic modulus of elasticity of ultrasonic transit time $R_{u,n}$. In this test procedure its relative change after n freeze-thaw cycles is calculated by the relation⁶:

$$R_{u,n} = \tau_n^2 \quad (5)$$

The average value for both transit axes gives the relative dynamic modulus of elasticity for the specimen. It is possible to express the relative dynamic modulus of elasticity as a percentage.

The mean and standard deviation of the relative dynamic modulus of elasticity for a test series must be determined. The results must be checked for outliers.

7.4.5 Criterion

7.4.5.1 Damage criterion

The concrete is defined as damaged when $R_{u,n}$ transgresses below the 0.8 level (respectively 80%)⁷.

(5) The change in transit length can be neglected.

(6) For this equation changes of density, size of specimen and Poisson's ratio are neglected. This is not a serious restriction since the detection of damage is the aim of the test and ultrasonic transit time is the relevant parameter. The dynamic modulus of elasticity is only a quantity which is a well known common engineering quantity.

(7) A relative dynamic modulus of 80% guarantees a sufficient selectivity compared to the undamaged concrete (100%), according to the precision data. See also Section 8.2.

7.4.5.2 Assessment of the internal damage

The criterion for assessing the internal damage is the number of freeze-thaw cycles when the damage criterion is reached. The number of freeze-thaw cycles can be calculated by linear interpolation between two measuring points adjacent to the damage criterion.

7.4.5.3 Rules for acceptance criterion

For the acceptance criterion, interested parties must agree upon a number of freeze-thaw cycles until which the damage criterion must not be transgressed below.

It must be taken into account that any deviations in the height of the standard specimen are significant and influence the acceptance criterion. Therefore, such results should only be evaluated by experts in the field of CIF testing.

7.5 Alternative methods

The alternative methods for determination internal damage are found in the annex.

8. PRECISION DATA OF CIF TEST FOR CONCRETE MIXTURES

8.1 General

Three different precision variables are distinguished: repeatability, reproducibility and scattering of laboratories with respect to each other. Using ISO 5725 as a guide, the precision data of the CIF test were found for various concrete mixtures according to Section 5.1.1.

8.2 Measurement of Internal damage – reference method (ultrasonic transit time)

The precision data for the relative dynamic modulus are:

Table 1 - Precision data according to ISO 5725. Measurement of relative dynamic modulus of elasticity (from ultrasonic transit time)		
Relative dynamic modulus	100 %	80 %
	standard deviations	
precision of repeatability s_r	0.7 %	4.8 %
precision of reproducibility s_R	0.9 %	6.2 %

These data are valid for concrete prepared according Section 5.1.1

The precision data can be expressed as:

$$s_r = -0.2046 R_{u,n} + 0.2122 \quad (R_{u,n} \text{ 0.80 to 1.0 with } R^2 = 0.85) \quad (6)$$

$$s_R = -0.2656 R_{u,n} + 0.2750 \quad (R_{u,n} \text{ 0.80 to 1.0 with } R^2 = 0.73) \quad (7)$$

where s_r and s_R denote the standard deviation of repeatability and reproducibility and $R_{u,n}$ is the relative dynamic modulus calculated with Equation (5).

REMARK: The precision data and the equations are based on the results of the inter-laboratory-test of RILEM TC IDC, including 7 institutes testing 3 different kinds of concrete series.

8.3 Measurement of moisture uptake

The precision data for the moisture uptake are given in Table 2. These data apply for laboratory concrete series which are measured according to Section 7.3.

Table 2 - Precision data according to ISO 5725. Measurement of moisture uptake			
Moisture uptake	0 to 0.5 m-%	0,5 to 1,5 m-%	> 1,5 m-%
	standard deviations		
precision of repeatability s_r	0.014 m-%	0.027 m-%	0.054 m-%
precision of reproducibility s_R	0.029 m-%	0.058 m-%	0.115 m-%

The precision data can be expressed as:

$$s_r = 0.0265 \Delta w_n + 0.0005 \quad (\Delta w_n \text{ 0 to 2.5 with } R^2 = 0.30) \text{ or } 0.09 \text{ m-\% as total} \quad (8)$$

$$s_R = 0.0569 \Delta w_n + 0.0008 \quad (\Delta w_n \text{ 0 to 2.5 with } R^2 = 0.30) \text{ or } 0.17 \text{ m-\% as total} \quad (9)$$

where s_r and s_R denote the standard deviation of repeatability and reproducibility and Δw_n is the moisture uptake during the freeze-thaw test.

REMARK: The precision data and the equations are based on the results of the inter-laboratory-test of RILEM TC IDC, including 9 institutes testing 3 different kinds of concrete series.

8.4 Measurement of scaling

The precision data apply for laboratory concrete series which are measured according to Section 7.2.

The precision data for surface scaling are only available in the range of scaling between 0 to 500 g/m².

$$s_{r500} = 120 \text{ g/m}^2 \quad (\text{CoV } 24\%)$$

$$s_{R500} = 160 \text{ g/m}^2 \quad (\text{CoV } 32\%)$$

The precision data for surface scaling is unavailable to date.

Additional precision data are available for the CDF-Test /5/.

8.5 Alternative methods

The precision data for the alternative methods can be found in the annex.

9. REPORT

The test report shall contain at least the following information:

1. A reference to this description.
2. Measures, mass, origin and marking of the specimens.
3. If concrete mixes or constituents are tested, the composition of the concrete.
4. The duration of drying storage.
5. The composition of the test liquid.
6. The number of freeze-thaw cycles carried out.
7. The change in calculated relative dynamic modulus of elasticity for each specimen as well as the mean value and standard deviation in % rounded to the nearest 1%, along with the number of freeze-thaw cycles carried out.
 - 7A. Alternative: Elastic modulus (described according to No. 7.) for the elastic modulus by transversal frequency.
 - 7B. Alternative: Length change data for each specimen as well as the mean value and standard deviation in %, reported as percent increase or decrease in linear dimension to the nearest

0.1 % along with the number of freeze-thaw cycles carried out, based on the initial measurement made at the end of the conditioning period.

8. The amount of scaled material for each specimen as well as the mean value and the standard deviation in g/m^2 rounded to the nearest 1 g/m^2 after termination of the test.
9. The mass of solution absorbed during the capillary suction period and during freeze-thaw cycles (frost-suction) for each specimen as well as the mean value and the standard deviation.
10. Visual assessment (cracks, scaling from aggregate particles) before the start and at least at the end of the test.
11. Any deviations from the standard test procedure.

Annex- alternative methods A and B

Alternative method A - Measurement of fundamental transverse frequency

a. General

Specimens having either very small or very large ratios of length to maximum transverse direction are frequently difficult to excite in the fundamental mode of vibration. The best results are obtained when this ratio is between 3 and 5.

The conditions of manufacture, the moisture content and other characteristics of the test specimens influence the results obtained.

Different computed values for the dynamic modulus of elasticity may result from widely different resonant frequencies of specimens of different sizes and shapes of the same concrete. Therefore, comparison of results from specimens of different sizes or shapes should be made with caution.

This dynamic elastic modulus cannot be directly correlated with the dynamic elastic modulus found by ultrasonic transit time for non-homogenous materials, i.e., with locally different degree of saturation or damaged specimens. In both cases it is theoretically assumed, that the material is homogeneous.

b. Standards

ASTM C 215-97 - Fundamental Transverse, Longitudinal, and Torsional Frequencies of Concrete Specimens (partly adopted and modified).

c. Definitions

Fundamental transverse frequency is the first frequency at which a specimen vibrates in transverse bending. At the fundamental transverse frequency there are two nodal points located approximately 22.4 percent of the specimen length from the ends of the specimen.

d. Equipment

1. *Fourier Analyzer* - Equipment capable of FFT analysis of vibrational input data must be used to convert time-domain measurements to frequency-domain response. The equipment must be capable of averaging multiple frequency response measurements from a single specimen prior to determination of fundamental frequency. The equipment must have at least two input channels, and must be able to use the signal from one channel to normalize the signal from a second channel. This allows multiple readings to be averaged even though the vibration responses may have been produced by different impact magnitudes. The equipment must also be able to use a minimal input level in one channel to trigger recording of data in all channels. The equipment must allow independent setting of the lower and upper limits of the frequency range in order to provide better resolution near the fundamental frequency. The equipment must have a maximum frequency capability of at least 1 kHz above the expected maximum fundamental frequency of the specimens being tested. A sensitivity of 0.1 to 1.0 AC volts for the excitation (hammer) channel and 0 to 5.0 AC volts for the vibration response channel (accelerometer) have been found to be appropriate for the hammer and accelerometer described below. The equipment must be capable of producing a visual display of the frequency response spectrum. This can be accomplished either directly by the equipment or through the use of a personal computer connected to the analyzer.
2. *Modally Tuned Impact Hammer* - The vibrations in the specimen being tested are produced by impact. The impact device must be capable of producing a flat frequency response over the entire frequency range being sampled. A modally tuned impact hammer with a mass of 140g and a frequency response of 0-8 kHz has been found to produce the appropriate impact. The impact tip of the hammer must be of sufficient hardness and appropriate shape to neither be damaged by

the specimen nor cause damage to the specimen when an impact of proper magnitude is produced. A spherical tip has not been found to be necessary. The hammer must be provided with an electronic load cell and appropriate power supply capable of producing an output voltage proportional to the magnitude of the impact with the specimen. The sensitivity of the load cell must be 10 to 15 mV/N.

3. *Accelerometer and Power Supply* - The vibration response of the specimen must be measured with an accelerometer having a flat base. The mass of the accelerometer must not exceed 3 g, and the upper range of its operating frequency must be at least 1 kHz above the maximum expected fundamental frequency. The fundamental frequency of the accelerometer must be at least twice the highest expected fundamental frequency of any of the specimens to be measured. The accelerometer must be provided with an appropriate power supply, and the output of the accelerometer/power supply combination must be at least 50 mV/g. Amplification of the accelerometer output may be necessary to achieve the proper output level.
4. *Specimen Support* - The support must permit the specimen to vibrate without significant restriction. This may be accomplished by supporting the specimen on knife-edges located near the nodal points or on a thick pad of sponge rubber. The support must be so dimensioned that its fundamental frequency falls outside the frequency range of use. An example for the reference specimen size is given in Fig. 10.

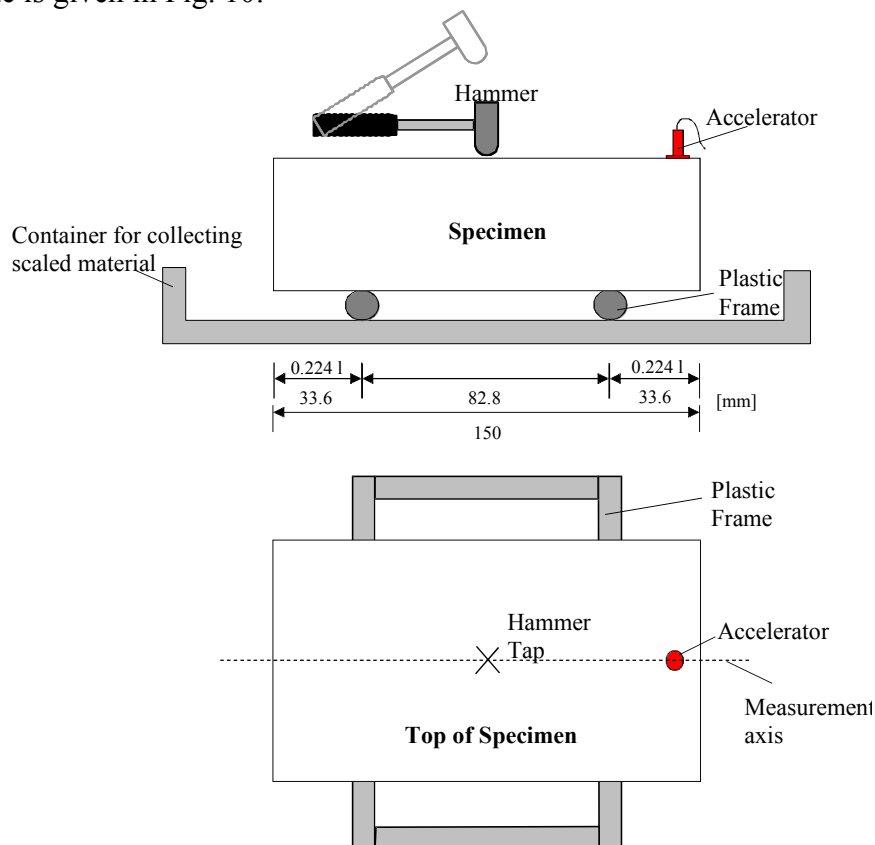

Fig. 10: Test equipment for measuring the fundamental transverse frequencies (reference specimens)

e. Determination of Transverse Frequency

1. Place the specimen on the support (plastic frame), with the test face down, in such a manner that it may vibrate without significant restriction in a free transverse mode.

2. Attach the accelerometer to the top surface of the specimen, close to the end and midway between the corners. Either a rubber band (around the end of the specimen) or adhesive wax can be used to hold the accelerometer in place.
3. The center of the top face of the specimen is lightly tapped with the instrumented hammer. The tap must be strong enough to produce an output voltage of 0.5 to 1 V. The visual display of the frequency response curve measured by the accelerometer can be used to determine if the tap produced a “clean hit”. Possible reasons for abnormal looking frequency response curves include not stopping the specimen vibration from a previous hit, and “double tapping” the specimen. A good tap should clearly indicate the fundamental transverse vibration⁸ at the portion of the curve with the highest amplitude.

f. Standard specimen

Size and casting of standard specimens is in accordance with Section 5.1.1. Deviations from this standard specimen are not covered by this recommendation and therefore, must be approved separately.

g. Evaluation of the internal damage

In this procedure the relative dynamic modulus of elasticity after n freeze-thaw cycles is calculated separately for each specimen by:

$$R_{f,n} = \left(\frac{f_n}{f_0} \right)^2 \quad (10)$$

$R_{f,n}$ is the relative dynamic modulus of elasticity

f_n is the fundamental frequency after n freeze-thaw cycles

f_0 is the fundamental frequency after re-saturation, before freeze-thaw cycles.

The mean and standard deviation of the relative dynamic modulus of elasticity over a test series must be determined. The results must be checked for outliers.

It is possible to express the relative dynamic modulus of elasticity in percent.

h. Damage criterion

Damage criterion is defined in accordance with Section 7.4.5.

i. Precision data

The precision data for the relative dynamic modulus at 80% are:

Table 3 - Precision data according to ISO 5725. Measurement of relative dynamic modulus of elasticity (from resonance frequency)		
Relative dynamic modulus	100 %	80 %
	standard deviations	
precision of repeatability s_F	0.09 %	4.4 %
precision of reproducibility s_R	0.17 %	6.6 %

(8) For fundamental transverse vibration, the nodal points are located 0.224 of the length of the specimen from each end (approximately the quarter points). Vibrations are a maximum at the ends approximately three fifths of the maximum at the centre, and zero at the nodal points. Therefore, movement of the pickup along the length of the specimen will inform the operator whether the vibrations observed are from the specimen vibrating in its fundamental transverse mode. For the reference specimen this means the nodal points are $0,224 \times 150 \text{ mm} = 33,6 \text{ mm}$ from the specimen ends. (Fig. 9)

The precision data for the resonance frequency can be given as equations. These data apply for laboratory concrete series which are measured according to the Annex, Alternative method A.

The precision data can be expressed as:

$$s_r = -0.2151 R_{f,n} + 0.2160 \quad (R_f \text{ 0.80 to 1.0 with } R^2 = 0.86) \quad (11)$$

$$s_R = -0.3199 R_{f,n} + 0.3216 \quad (R_f \text{ 0.80 to 1.0 with } R^2 = 0.92) \quad (12)$$

where s_r and s_R denote the standard deviation of repeatability and reproducibility.

REMARK: The equations are based on the results of the inter-laboratory-test of RILEM TC IDC, including 4 institutes testing 3 different kinds of concrete series.

Alternative method B - Measurement of length changes

Internal damage due to frost action, especially when the damage is in the aggregates rather than the cement paste, can lead to considerable expansion in the concrete. Length change measurements can be used to quantify internal damage due to frost.

a. Standards

1. ASTM C 341-89 - Length Change of Drilled or Sawed Specimens of Cement Mortar and Concrete (partly adopted and modified)
2. ASTM C 490-89 - Apparatus for Use in Measurement of Length Change of Hardened Cement Paste, Mortar, and Concrete (partly adopted and modified)
3. ISO 4762/1997 - Hexagon socket head cap screw

b. Definitions

1. *Length change* - an increase or decrease in the linear dimension of a test specimen, measured along the longitudinal axis, due to causes other than applied load.
2. *Gauge length* is the distance between the reference points which are located at the exposed ends of the gauge studs.

c. Equipment

1. *Length Comparator* - The comparator for measuring length change of specimens must be designed to accommodate the size of specimen employed and permit a positive means of contact with the gauge studs and convenient and rapid measurement of lengths of specimens. With respect to the size of the reference specimens, the dimension of the comparator must be 170 mm or more.

The comparator for measuring length changes of specimens must provide a dial micrometer or other measuring device graduated to read in 0.01 mm, accurate within 0.001 mm in the measuring device to allow for small variations in the gauge length of various specimens.

2. *Gauge Studs* - The contact terminals must be conical, heat-treated surfaces as shown in Fig. 11 (following ISO 4762).

The gauge studs must be of stainless steel or other corrosion-resistant metal of similar hardness. The gauge studs must be set so that their principal axes coincide with the principal axis of the test specimen. For the reference specimens the gauge studs must extend into the specimen 10 ± 2 mm and the distance between the inner ends of the gauge studs must be 13 ± 0.5 cm.

3. *Reference bar* - The design must provide a means for checking the measuring device at regular intervals. The reference bar must have an overall length of approximately the same as the average gauge lengths of the specimens being tested. The bar must be of a steel alloy having a coefficient of thermal expansion not greater than two millionths per degree Celsius. Each end must be machined to the same shape as the contact end of a gauge stud, and must be heat-treated, hardened, and then polished. The reference bar must have a positing mark near one end, and must be placed in the instrument in the same position each time a length measurement is taken. The dial gauge setting of the measuring device must be checked by use of the reference bar at least at the beginning and end of the readings made within a half day when the apparatus is kept in a room maintained at constant temperature. It must be checked more often when kept in a room where the temperature is not constant.

d. Setting Gauge Studs

Gauge studs must be glued with epoxy resin in drilled holes.

The holes must be drilled about 1 mm bigger in diameter than the studs. The location and depth of holes must be as given in Fig. 11. The depth of the holes must be such that the gauge studs will project from 3 to 5 mm beyond the ends of the specimen. Both pairs of holes must be positioned in a plane containing the longitudinal axis of the specimen and space to be conform to the length of the comparator. The center of each hole must be at least approximately 25 mm from the end of the specimen. The depth of the hole must preferably be such that the top surface of the gauge stud can extend about 3 mm beyond the surface of the specimen.

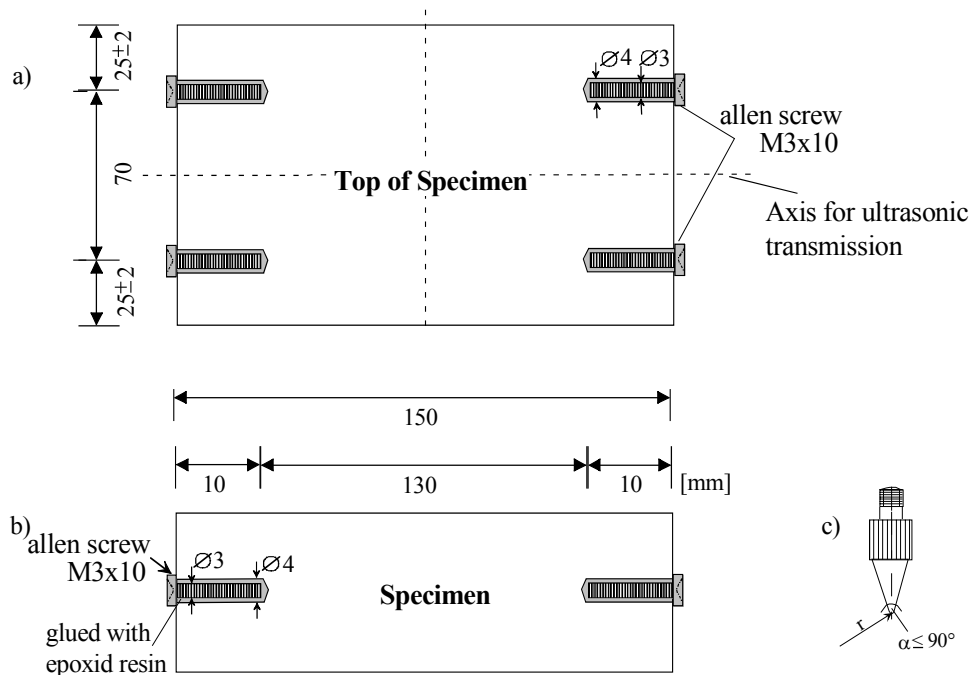

Fig 11: Test equipment for measuring the length changes

- a) Outline of prepared specimen
- b) Sidewise view of prepared specimen
- c) Sensing device for dial gauge (comparable arrangement)

e. Determination of Gauge Length of Specimens

Specimens or the comparator must be rotated slowly while measuring the length. The minimum reading of the dial must be recorded if the rotation causes a change in the dial reading. Specimen must be placed in the instrument with the same end up each time a length measurement is taken.

In the case of specimens having gauge studs on the sides, determine the gauge length by direct measurement between the reference points with a suitable scale. Determine the gauge length of specimens having gauge studs in the ends by first measuring the distance between the ends of the gauge studs with suitable calipers and subtracting the lengths of the two gauge studs (see Fig. 11).

f. Standard specimen

Size and casting of standard specimens is in accordance to Section 5.1.1. Deviations from this standard specimen are not covered by this recommendation and therefore, must be approved separately.

g. Evaluation of Length Change

The calculation of length change is done by following equation:

$$\Delta l_n = \frac{l_n - l_0}{l_s} * 100 \quad (13)$$

Δl_n is the relative length change after n freeze-thaw cycles, in %

l_n is $l_{cs} - l_1 + l_2$

l_0 is the comparator length of test specimens before first ftc and after the pre-saturation ($l_0 = l_n$ (0 ftc))

l_{cs} is the comparator length of the calibration bar

l_1 is the comparator length of the calibration bar after n freeze-thaw cycles

l_2 is the comparator length of specimen after n freeze-thaw cycles

l_s is the total length of specimen before gluing the lateral sealing (accuracy 0.5 mm)

h. Damage criterion

Damage criterion has to be defined separately.

i. Precision data

Precision data for the length change are not yet available.