

# DYNAMIC VOLTAGE STABILITY ANALYSIS IN MULTI-MACHINE POWER SYSTEMS

Li-Jun Cai

Department of Electrical Engineering  
University of Duisburg-Essen  
47057 Duisburg, Germany  
cailijun@uni-duisburg.de

István Erlich

Department of Electrical Engineering  
University of Duisburg-Essen  
47057 Duisburg, Germany  
erlich@uni-duisburg.de

**Abstract** – This paper presents a novel approach for power system dynamic voltage stability analysis based on the multi-input multi-output (MIMO) transfer function. The MIMO system is defined taking into account the critical nodal voltages as outputs and possible control variables as the input. Based on the modal analysis and singular value analysis, the dynamic voltage stability analysis is carried out. The proposed approach takes the advantages of the classical static voltage stability analysis and the modern multi-variable feedback control theory. The singular values and singular vectors are calculated for frequencies corresponding to the critical system modes. The output singular vectors provide an overview as to which outputs and thus which nodes are most affected by the voltage instability. Using the magnitudes of the input singular vectors the most suitable inputs for countermeasures can be selected. The proposed method is also applicable to very large systems.

**Keywords:** *Dynamic voltage stability, Singular value analysis, Modal analysis, Power system dynamics, Dynamic voltage stability index, Multi-variable feedback control*

## 1 INTRODUCTION

A large number of researches were performed in the area of voltage stability. Most of them treat the voltage stability problem with static analysis methods based on the study of the reduced ( $V-Q$ ) Jacobian matrix, and by performing modal analysis [1-6]. Thus, the bus, branch and generator participation factors on the static voltage stability can be obtained. Moreover, the stability margin and the shortest distance to instability can also be determined [6].

However, power system is a typical large dynamic system and its dynamic behavior has great influence on the voltage stability. The latest blackouts have shown that voltage stability is very closely associated with issues of frequency and angle stability [7,8]. Therefore, in order to get more realistic results it is necessary to take the full dynamic system model into account. Some researches have been performed on the dynamic voltage stability analysis [1,5,6,9]. The general structure of the system model used is similar to that for transient stability analysis. The overall system equations comprise a set of first-order differential equations plus the algebraic equations (DAEs) [6]. However, for voltage stability analysis, special attention should be paid to issues of

voltage and reactive power control and load behavior. In [9], the objective of dynamic voltage stability is achieved by minimizing oscillations of the state and network variables. Then, a parameter optimization technique is applied for limiting the magnitude of oscillations. In [10], the voltage stability is decoupled from the angle dynamics. The authors are assuming that all electromechanical oscillations are stable. By neglecting the power-angle dynamics, the voltage response of the unregulated power system can be approximated by the eigenvalues of the Voltage Stability Matrix [10].

However, in large power systems, the dynamic voltage stability is associated with different modes of oscillations. Although there is extensive literature on voltage stability, very few deal with this issue.

In this paper, a novel approach for the assessment of dynamic voltage stability is proposed. The method takes the advantages of modern multi-variable control theory. Based on the MIMO transfer function, interactions between properly defined input and output variables affecting dynamic voltage stability can be analyzed at different frequencies.

This paper is organized as follows: Following the introduction, the classic dynamic and static voltage stability analyses are described in section 2. Then in section 3, the proposed dynamic voltage stability modeling is introduced. The singular value analysis for dynamic voltage stability assessment is discussed in section 4 and 5. Simulation results are given in section 6. Finally, brief conclusions are deduced.

## 2 CLASSICAL DYNAMIC AND STATIC VOLTAGE STABILITY ANALYSES AND CONTROL

### 2.1 Dynamic voltage stability analysis

The mathematical model for the dynamic voltage stability study of a power system comprises a set of first order differential equations and a set of algebraic equations [1,6]:

$$\dot{\mathbf{x}} = \mathbf{f}(\mathbf{x}, \mathbf{y}) \quad (1)$$

$$0 = \mathbf{g}(\mathbf{x}, \mathbf{y}) \quad (2)$$

where

$\mathbf{x}$  is the state vector of the system

$\mathbf{y}$  vector containing bus voltages

Equations (1) and (2) are usually solved in the time-domain by means of the numerical integration and power flow analysis methods [5,6].

The steady state equilibrium values ( $\mathbf{x}_0 \mathbf{y}_0$ ) of the dynamic system can be evaluated by setting the derivative in Equation (1) to zero. Through linearization about ( $\mathbf{x}_0 \mathbf{y}_0$ ), Equations (1) and (2) are expressed as follows [1,5]:

$$\frac{d\Delta\mathbf{x}}{dt} = \mathbf{A}\Delta\mathbf{x} + \mathbf{B}\Delta\mathbf{y} \quad (3)$$

$$0 = \mathbf{C}\Delta\mathbf{x} + \mathbf{D}\Delta\mathbf{y} \quad (4)$$

Further, by eliminating  $\Delta\mathbf{y}$ , the linearized state equation can be written as [1,5]:

$$\frac{d\Delta\mathbf{x}}{dt} = (\mathbf{A} - \mathbf{B}\mathbf{D}^{-1}\mathbf{C})\Delta\mathbf{x} = \tilde{\mathbf{A}}\Delta\mathbf{x} \quad (5)$$

The static bifurcation will occur when  $\det(\mathbf{D}) = 0$ . For the dynamic bifurcation phenomenon, it is always assumed that  $\det(\mathbf{D}) \neq 0$  and that  $\mathbf{D}^{-1}$  exists [1,5].

By analyzing the eigenvalues of  $\tilde{\mathbf{A}}$ , dynamic voltage stability analysis can be performed.

## 2.2 Static voltage stability analysis

The static voltage stability analysis is based on the modal analysis of the power flow Jacobian matrix, as given in Equation (6) [6]:

$$\begin{bmatrix} \Delta\mathbf{P}_{PQ,PV} \\ \Delta\mathbf{Q}_{PQ} \end{bmatrix} = \begin{bmatrix} \mathbf{J}_{P\theta} & \mathbf{J}_{PV} \\ \mathbf{J}_{Q\theta} & \mathbf{J}_{QV} \end{bmatrix} \cdot \begin{bmatrix} \Delta\boldsymbol{\theta} \\ \Delta\mathbf{V}_{PQ} \end{bmatrix} \quad (6)$$

where

- $\Delta\mathbf{P}_{PQ,PV}$  incremental change in bus real power
- $\Delta\mathbf{Q}_{PQ}$  incremental change in bus reactive power
- $\Delta\boldsymbol{\theta}$  incremental change in bus voltage angle
- $\Delta\mathbf{V}$  incremental change in bus voltage magnitude

The elements of the Jacobian matrix represent the sensitivities between nodal power and bus voltage changes [6]. Power system voltage stability is largely affected by the reactive power. Keeping real power as constant at each operating point, the  $Q-V$  analysis can be carried out. Assuming  $\Delta\mathbf{P}_{PQ,PV} = 0$ , it follows from Equation (6) [4,6]:

$$\Delta\mathbf{Q}_{PQ} = [\mathbf{J}_{QV} - \mathbf{J}_{Q\theta} \cdot \mathbf{J}_{P\theta}^{-1} \cdot \mathbf{J}_{PV}] \cdot \Delta\mathbf{V}_{PQ} = \mathbf{J}_R \cdot \Delta\mathbf{V}_{PQ} \quad (7)$$

and

$$\Delta\mathbf{V}_{PQ} = \mathbf{J}_R^{-1} \cdot \Delta\mathbf{Q}_{PQ} \quad (8)$$

Based on the  $\mathbf{J}_R^{-1}$ , which is the reduced  $V-Q$  Jacobian matrix, the  $Q-V$  modal analysis can be performed. Therefore, the bus, branch and generator participation factors are obtained. Moreover, the stability margin and the shortest distance to instability will be determined [4-6].

As discussed in [2,3,12], the application of singular value analysis to  $\mathbf{J}_R^{-1}$  also allows the static voltage stability analysis.

## 2.3 Voltage stability control

In order to prevent voltage collapse, different measures can be applied [5,6]. The reactive power compensation, under-voltage load shedding and the control of transformer tap-changers are the most important control features for enhancing the static voltage stability [5,6,9]. Furthermore, with the development of power electronics, FACTS (Flexible AC Transmission Systems) devices, i.e. SVC (Static Var Compensation), are also recognized as important tools for the dynamic voltage stability control.

## 3 DYNAMIC VOLTAGE STABILITY MODELING – A NOVEL APPROACH

In this paper, we suggest to carry out voltage dynamic stability analysis based on the MIMO transfer function, which is widely used in control engineering. For this analysis, a detailed dynamic power system model including generators, governors, static exciters, power system stabilizers (PSS) and nonlinear voltage and frequency dependent loads is necessary. Furthermore, dynamic loads may also be included. In general, the dynamic models described by Equations (1) and (2) must consider all relevant issues affecting voltage stability.

As the first step, variables that affect dynamic voltage stability must be selected as input variables to the MIMO system. These are usually the real and reactive power controls of selected generators and loads. Some other variables, such as the tap-changer position and the SVC control signals, can also be included as inputs. The voltage magnitudes at the most critical nodes are considered as output signals. Since the number of input and output variables can usually be constrained to a small range, large power systems can also be analyzed using the proposed method.

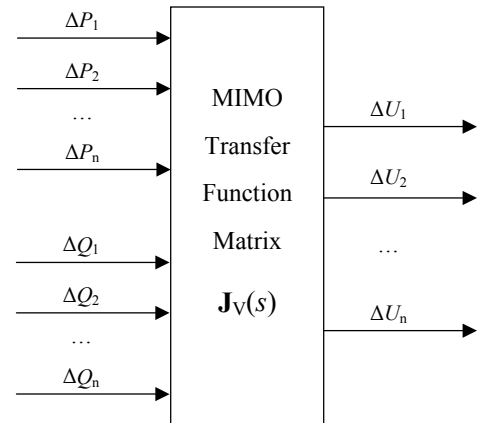

Figure 1: Dynamic voltage stability modeling

In this study, a MIMO system transfer function matrix is employed by using all the generation and load controls as the input signals. Also the set of output signals is extended to all bus voltages due to the small size of the simulated power system. The corresponding transfer function matrix, which is described by Equation (9), is shown in Figure 1.

$$\begin{bmatrix} \Delta U_1 & \Delta U_2 & \dots & \Delta U_n \end{bmatrix}^T = \mathbf{J}_V(s) \cdot \begin{bmatrix} \Delta P_1 & \Delta P_2 & \dots & \Delta P_n \mid \Delta Q_1 & \Delta Q_2 & \dots & \Delta Q_n \end{bmatrix}^T \quad (9)$$

where

$$\mathbf{J}_V(s) = \begin{bmatrix} f_{P1\_U1}(s) & \dots & f_{Pn\_U1}(s) & \mid & f_{Q1\_U1}(s) & \dots & f_{Qn\_U1}(s) \\ f_{P1\_U2}(s) & \dots & f_{Pn\_U2}(s) & \mid & f_{Q1\_U2}(s) & \dots & f_{Qn\_U2}(s) \\ \dots & \dots & \dots & \mid & \dots & \dots & \dots \\ f_{P1\_Un}(s) & \dots & f_{Pn\_Un}(s) & \mid & f_{Q1\_Un}(s) & \dots & f_{Qn\_Un}(s) \end{bmatrix} \quad (10)$$

is a  $n_{Output} \times n_{Input}$  transfer function matrix.

Each sub transfer function in the  $\mathbf{J}_V(s)$  can be obtained by applying numerical methods to the power system dynamic model.

## 4 SINGULAR VALUE ANALYSIS FOR DYNAMIC VOLTAGE STABILITY

### 4.1 Singular value decomposition (SVD)

In order to analyze the MIMO system, singular value decomposition (SVD) of  $\mathbf{J}_V(s)$  is carried out at every fixed frequency [3,12,13]:

$$\mathbf{J}_V(s) = \mathbf{U}\mathbf{\Sigma}\mathbf{V}^T \quad (11)$$

where

$\mathbf{\Sigma}$  is a  $n_{Output} \times n_{Input}$  matrix with  $k = \min \{ n_{Output}, n_{Input} \}$  non-negative singular values,  $\sigma_i$ , arranged in descending order along its main diagonal; the other entries are zero. The singular values are the positive square roots of the eigenvalues of  $\mathbf{J}_V^T(s) \times \mathbf{J}_V(s)$ , where  $\mathbf{J}_V^T(s)$  is the complex conjugate transpose of  $\mathbf{J}_V(s)$  [13].

$$\sigma_i(\mathbf{J}_V(s)) = \sqrt{\lambda_i(\mathbf{J}_V^T(s) \times \mathbf{J}_V(s))} \quad (12)$$

$\mathbf{U}$  is a  $n_{Output} \times n_{Output}$  unitary matrix of output singular vectors,  $\mathbf{u}_i$

$\mathbf{V}$  is a  $n_{Input} \times n_{Input}$  unitary matrix of input singular vectors,  $\mathbf{v}_i$

### 4.2 Singular vectors

The column vectors of  $\mathbf{U}$ , denoted  $\mathbf{u}_i$ , represent the directions of the output variables. They are orthogonal and of unit length. Likewise, the column vectors of  $\mathbf{V}$ , denoted  $\mathbf{v}_i$ , represent the directions of input variables. These input and output directions are related through the singular values [13].

For dynamic analysis, the singular values and their associated directions vary with the frequency. In power system dynamic voltage stability analysis, critical frequencies corresponding to poorly damped dominant modes must be considered.

By analyzing the maximum singular values and their related input and output singular vectors, the relationship between input and output can be obtained at each frequency. The output singular vector shows at which bus the voltage magnitude is the most critical. The input singular vector indicates which input has the greatest influence on the corresponding output. Therefore, by means of the singular value analysis, the dynamic voltage stability can be performed.

## 5 SIMULATION RESULTS

### 5.1 Power system model and analysis procedure

A typical four-machine two-area power system model [6,11], as shown in Figure 2, is used for demonstration of the proposed method. The corresponding dynamic model consists of generators described by 6<sup>th</sup> order model, governors, static exciters, power system stabilizers (PSS) and nonlinear voltage and frequency dependent loads. The detailed generator, controller and load models can be found in [6,11].

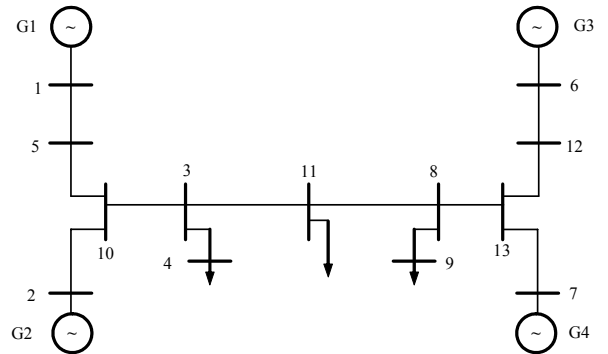

Figure 2: Four-machine two-area power system model

The dynamic voltage stability assessment of the test power system will be performed in the following steps:

- Static voltage stability analysis:

In large power systems, this step can be used for selecting the observed nodes and suitable control input variable for detailed dynamic voltage stability analysis.

- Modal analysis to find the critical modes of oscillations: Sometimes, the frequency range of critical

modes is known, so that the detailed modal analysis can be omitted.

- Calculation of the transfer function matrix  $\mathbf{J}_V(s)$  and SVD at critical frequencies.
- Find the critical buses, which have the most severe dynamic voltage stability problem.
- Find the best input variables allowing improvement of voltage stability.

### 5.2 Static voltage stability analysis – singular value approach

For the static voltage stability analysis, since the reduced Jacobian matrix  $\mathbf{J}_R^{-1}$ , as shown in Equation (8), is a square matrix, both modal analysis and singular value analysis can be applied. Based on the theory provided in [2,3,12], the static voltage stability is analyzed using the singular value approach in this research.

Simulation results are shown in Figure 3. The maximum singular value is 0.14. The corresponding maximum output singular vector is 0.55 and it associates with Bus 11. This means that disturbances on reactive loads will cause the largest variation on the voltage magnitude at Bus 11.

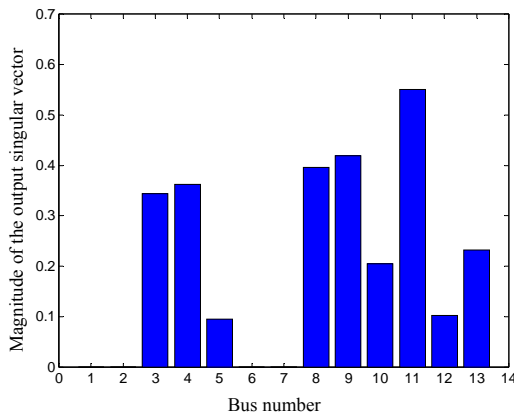

**Figure 3:** Output singular vector plot for the static voltage stability analysis

### 5.3 Dynamic voltage stability analysis – modal analysis and singular value approach

#### 5.3.1 Modal analysis

Modal analysis is carried out to find the critical modes of oscillations. The critical eigenvalues of the power system are given in Figure 4.

Due to the PSS controller, all modes of oscillations are well damped in the test system. However, the PSS controller has negative influences on some exciter modes. Although the exciter mode 1 and the inter-area mode have sufficient damping ratio, they have greater influences on the dynamic voltage stability than the other modes, as can be seen from the singular values in the next section.

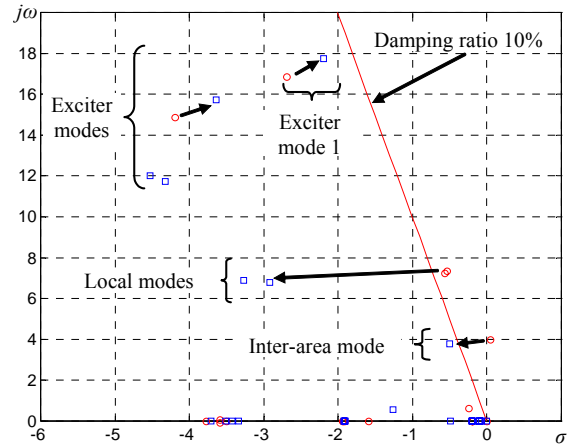

**Figure 4:** Critical eigenvalues of the power system

- : Eigenvalues with PSS controller
- : Eigenvalues without PSS controller

As shown in Figure 4, the exciter mode 1 has a damping ratio of 11.93% and the oscillation frequency is about 2.82Hz. The inter-area mode has a damping ratio of 13.63% and the corresponding oscillation frequency is about 0.57Hz.

#### 5.3.2 Singular value analysis

Based on the detailed dynamic power system model, the transfer function matrix  $\mathbf{J}_V(s)$  can be obtained using the numerical method. The maximal singular value of  $\mathbf{J}_V(s)$  provides the maximal gain between input and output variables. It describes how the observed outputs can be influenced by the inputs [13]. The maximal singular value of  $\mathbf{J}_V(s)$  over the frequency range of [0.01Hz~100Hz] is shown in Figure 5. It is obvious that the peaks of the maximal singular value plot correspond to the inter-area mode and exciter mode 1 respectively.

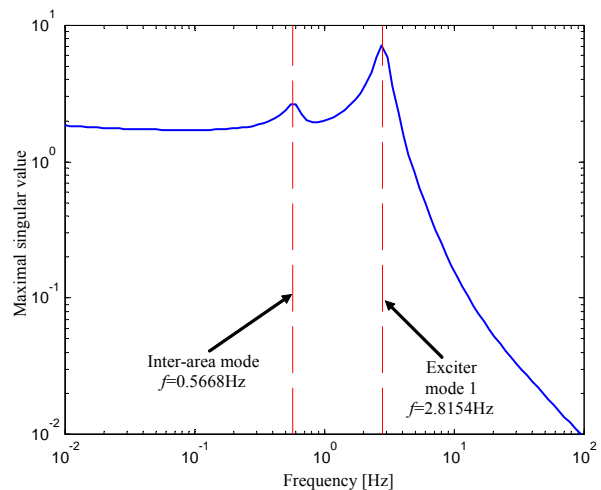

**Figure 5:** Maximal singular value plot

Therefore, the singular value analysis is carried out for the two critical oscillation mode frequencies.

The output singular vector corresponding to the maximum singular value at the exciter mode frequency is given in Figure 6. It can be seen that the buses 7, 8, 9 and 13 are related to the dynamic voltage stability with Bus 8 standing out as the most critical. The input singular vectors associated with this mode shows that the input signals of  $Q_{G4}$ ,  $Q_{G2}$ ,  $Q_{G3}$  and  $Q_{G1}$  (Input number 26, 24, 25 and 23) are the most suitable signals for this mode of dynamic voltage stability control. Other input signals have relative weak influences, as can be seen in Figure 7.

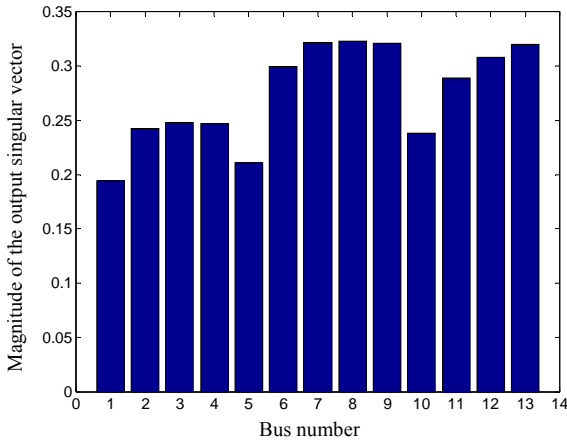

**Figure 6:** Output singular vector associated with exciter mode 1

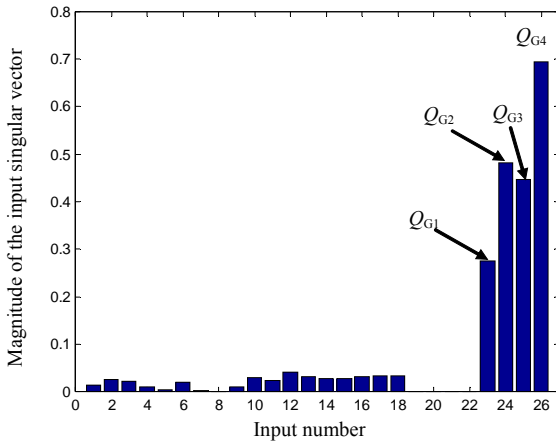

**Figure 7:** Input singular vector associated with exciter mode 1

The critical output singular vector associated with the inter-area mode is given in Figure 8. From this follows that the bus 11 is the most critical one. In comparison with the exciter mode 1, this mode has larger output singular vectors.

The input singular vectors, as can be seen in Figure 9, with this mode shows that the input signal of  $Q_{G2}$ ,  $Q_{G1}$ ,  $Q_{G4}$  and  $Q_{G3}$  (Input number 24, 23, 26 and 25) are the most suitable signals for dynamic voltage stability control.

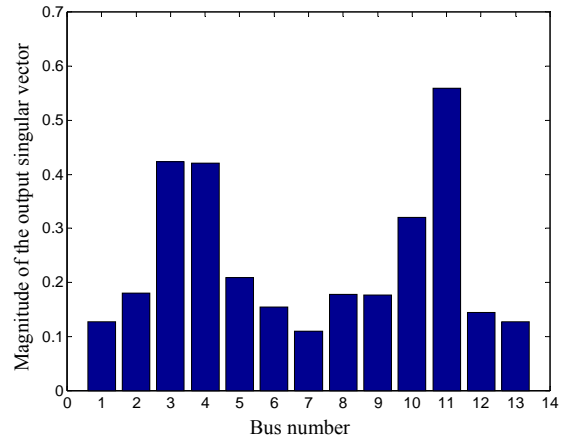

**Figure 8:** Output singular vector associated with inter-area mode

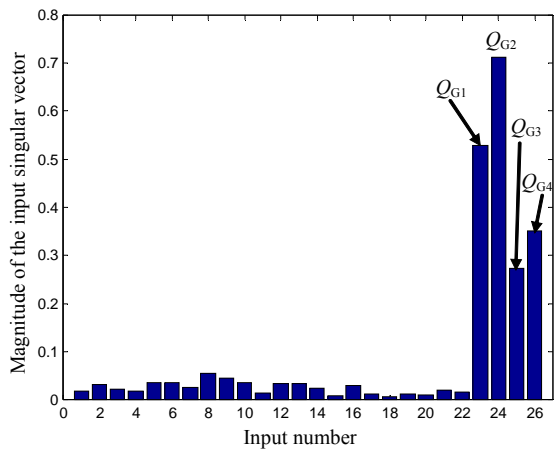

**Figure 9:** Input singular vector associated with inter-area mode

As can be seen from the input singular vector plots given in Figure 7 and Figure 9, the generator reactive power controls (Input number 23-26) will always have maximum influence on the dynamic voltage stability.

#### 5.4 Comparison of the static and dynamic voltage stability analysis methods

In order to compare the results of the static and dynamic voltage stability analyses, the static behavior of the MIMO transfer function matrix  $J_V(s)$  is analyzed ( $s=0$ ). The simulation result is shown in Figure 10.

For the static voltage stability assessment discussed in section 5.2, the generators G1~G4 (Buses 1, 2, 6, 7) are not included because they are considered as PV nodes. However, in the dynamic system model the voltages of these buses are not fixed and can be controlled. Therefore, they appear with non-zero values in the singular vectors shown in Figure 10. In comparison with the simulation result of static voltage stability analysis (Figure 3), it can be realized that the results are similar: The most critical node in both cases is Bus 11. How-

ever, instead of Bus 8 and Bus 9 in the static voltage stability analysis, Bus 3 and Bus 4 come to be the second critical nodes. The other nodes have the same participation with regard to voltage stability.

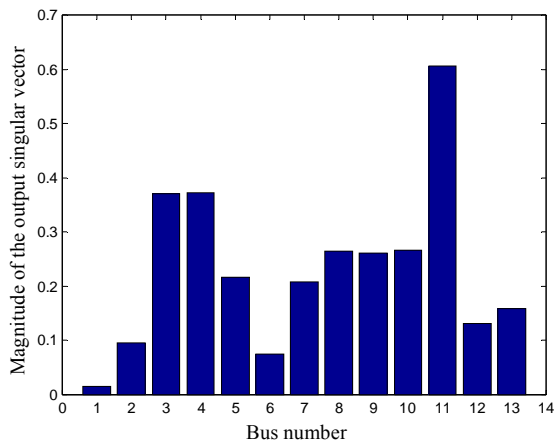

**Figure 10:** Output singular vector of the transfer function matrix  $J_V(s)$  when  $s=0$

## 6 CONCLUSION

This paper suggests the application of singular value analysis to a properly defined MIMO system model for power system dynamic voltage stability studies. The output variables of the MIMO system are chosen as the most critical node voltages concerning voltage stability issues. The inputs are selected due to their capability of impacting the outputs. Because in practical systems the focus is always on a few selected input/output variables, the method is always applicable to very large systems. For calculation of the transfer matrix, numerical methods based on a dynamic system model can be used, which is usually prepared for time domain simulation studies. The analysis has to be carried out at frequencies corresponding to critical and dominant modes. From the output singular vectors it can be seen how the selected nodes are affected by the voltage stability problem. The elements of the input singular vector indicate the impact of the corresponding inputs on the outputs. Therefore input singular vectors can be used for selecting the most suitable variables for voltage stability control.

## REFERENCES

[1] Byung Ha Lee and Kwang Y. Lee, "A study on voltage collapse mechanism in electric power systems," *IEEE Trans. Power Systems*, vol. 6, pp. 966-974, August 1991.

[2] P-A Löf, G Andersson and D. J. Hill, "Voltage stability indices for stressed power systems," *IEEE Trans. Power Systems*, vol. 8, pp. 326-335, February 1993.

[3] P-A Löf, G Andersson and D J Hill, "Voltage dependent reactive power limits for voltage stability studies," *IEEE Trans. Power Systems*, vol. 10, pp. 220-228, February 1995.

[4] B. Gao, G.K. Morison and P. Kundur, "Voltage stability evaluation using modal analysis," *IEEE Trans. Power Systems*, vol. 7, pp. 1529-1542, November 1992.

[5] Thierry Van Cutsem and Costas Vournas, *Voltage stability of the electric power systems*, Kluwer academic publishers, Boston/London/Dordrecht, ISBN 0-7923-8139-4.

[6] P. Kundur, *Power system stability and control*, McGraw-Hill, Inc, ISBN 0-07-035958-X.

[7] UCTE, "Final report of the investigation committee on the 28 September 2003 black in Italy," April 2004.

[8] U.S.-Canada power system outage task force, "Final report on the August 14, 2003 black in the United States and Canada: Causes and Recommendations," April 2004.

[9] Byung Ha Lee and Kwang Y. Lee, "Dynamic and static voltage stability enhancement of power systems," *IEEE Trans. Power Systems*, vol. 8, pp. 231-238, February 1991.

[10] C. D. Vournas, "Voltage stability and controllability indices for multimachine power systems," *IEEE Trans. Power Systems*, vol. 10, pp. 1183-1194, August 1995.

[11] G. Rogers, *Power System Oscillations*, Kluwer Academic Publishers, ISBN: 0-7923-7712-5, December 1999.

[12] P-A Löf, T. Smed, G. Andersson and D. J. Hill, "Fast calculation of a voltage stability index," *IEEE Trans. Power Systems*, vol. 7, pp. 54-64, February 1992.

[13] S. Skogestad and I. Postlethwaite, *Multivariable feedback control – Analysis and design*, John Wiley & Sons, ISBN: 0-471-94330-4, July 1996.

[14] Lijun Cai, *Robust coordinated control of FACTS devices in large power systems*, Logos Verlag, Berlin, ISBN: 3-8325-0570-9, 2004.

[15] Jovica V. Milanovic and Alfonso C. Serrano Duque, "Identification of Electromechanical Modes and Placement of PSSs Using Relative Gain Array," *IEEE Trans. Power Systems*, vol. 19, pp. 410-417, February 2004.