

Mode Selective Damping of Power System Electromechanical Oscillations Considering Time Delay Uncertainty in Supplementary Remote Signals

A. A. Hashmani, I. Erlich

ashfaque.hashmani@uni-due.de, istvan.erlich@uni-due.de
Institute of Electrical Power Systems (EAN),
University Duisburg-Essen, 47057-Duisburg, Germany

Abstract: This paper presents the design of H_∞ -based local decentralized power system stabilizer (PSS) controllers for large-scale power systems, using selected suitable remote signals from the whole system as supplementary inputs, for a separate better damping of specific inter-area modes, considering uncertainty in time delay. System identification technique is used for deriving lower order state-space models suitable for control design. The PSS controller uses only those local and remote input signals in which the assigned single inter-area mode is most observable and is located at a generator which is most effective in controlling that mode. The PSS controller, designed for a particular single inter-area mode, also works mainly in a frequency band given by the natural frequency of the assigned mode. The effectiveness of the resulting PSS controllers is demonstrated through digital simulation studies conducted on a sixteen-machine, three-area test power system.

Keywords: very large power systems, inter-area oscillations, PSS, remote signals, wide area measurements, uncertainty in time delay, robust H_∞ control

1. INTRODUCTION

Weakly damped low frequency inter-area oscillations, inherent to large interconnected power systems during transient conditions, are not only dangerous for the reliability and performance of such systems but also for the quality of the supplied energy. With the heavier power transfers ahead, the damping of these oscillations will decrease unless new lines are built (construction of new lines is restricted by environmental and cost factors) or other heavy and expensive high-voltage equipment such as series-compensation is deployed. Therefore, the achievement of maximum available transfer capability as well as a high level of power quality and security requires better coordinated protection and system stability control which leads to damping improvement.

Figure 1 and 2 shows the time-domain behaviour of the oscillations for the frequency and electrical power and rotor mode shape respectively with the East (Poland)-West (Spain) mode excited. The behaviours show that the group of generators on the East side (Poland) are swinging against the group of generators on the West side (Spain). Thus, the best signal to be used as an input to the controller, for damping the dominant inter-area mode, would be from the location where the oscillations are well observable. Wide area measurement (WAM) technologies using phasor measurement units (PMUs) can deliver synchronous control signals at high speed (Heydt et al., 2001). PMUs are deployed at strategic locations on the grid to obtain a coherent picture of the entire network in real time (Heydt et al., 2001). PMUs measure voltages and currents at different locations of the grid. Global positioning system (GPS) technology ensures proper time synchronization among several global signals (Heydt et al., 2001). The measured global signals are then transmitted via

modern telecommunication equipment to the controllers. Due to the transmission and processing of remote signals in WAMS, these may arrive after a certain communication delay. It is found that a controller designed for delay-free system if applied to the delayed-input system, the closed-loop system may lose stability. Time delay can make a control system to have less damping and there is a danger of losing synchronism. The design of a controller, therefore, must take into account this time delay.

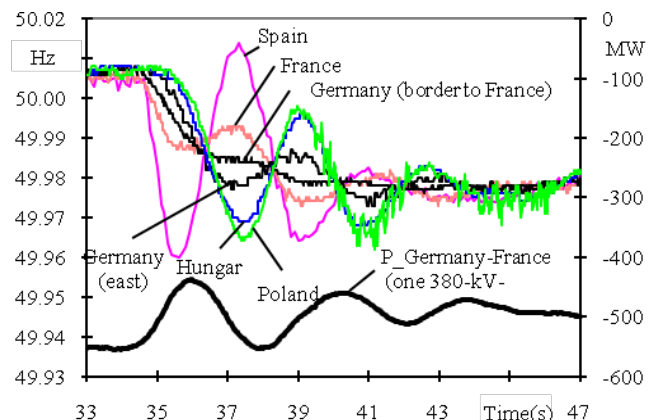

Fig. 1. Time-domain behaviour of the oscillations for the frequency and electrical power with the East (Poland)-West (Spain) mode excited (RWE, Dr. Grebe)

The mode selective damping of power system electromechanical oscillations using supplementary remote signals is presented in (Hashmani and Erlich, 2010). This paper presents the extension of the scheme given in (Hashmani and Erlich, 2010) to large-scale power systems.

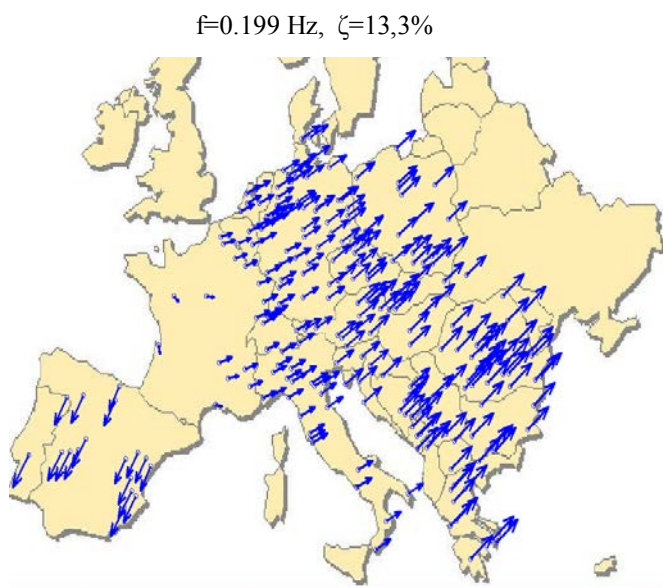

Fig. 2. Rotor mode shape with the East (Poland)-West (Spain) mode excited

This paper deals with the design of local decentralized PSS controllers using remote signals as supplementary inputs, for a better damping of inter-area oscillations in a large-scale power system considering uncertainty in time delay, in a manner that each decentralized PSS controller is designed separately for each of the inter-area modes of interest. LFT method is used to describe uncertainty in time delay (Hashmani and Erlich, 2009). The basic architecture (Hashmani and Erlich, 2008) used in this work is shown in Fig. 3. PSS inputs are formed by measured variables coming from the whole system, i.e., also from remote generators (Hashmani and Erlich, 2008). Thus, each PSS receives more complete measurement information about the inter-area oscillations to be damped. H_∞ -based robust control technique is used to design the proposed PSS controllers. Digital simulation studies on a sixteen-machine, three-area test power system are conducted to investigate the effectiveness of proposed controllers during system disturbances.

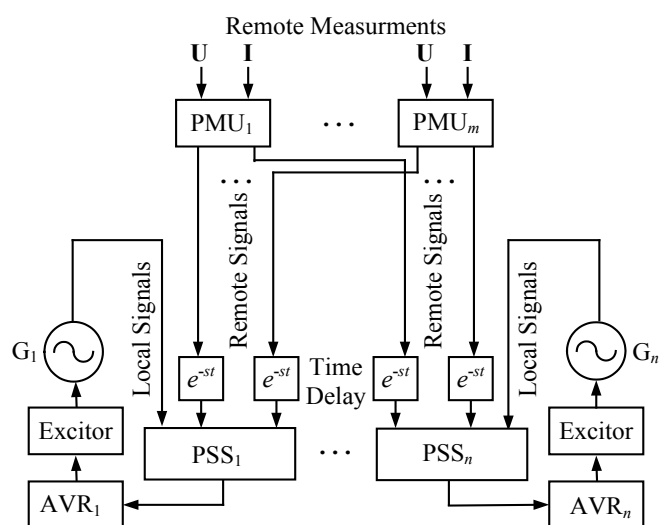

Fig. 3. Multi-machine power system with PSS using WAMs

The rest of the paper is organized as follows. In Section 2, concept of mode selective damping is presented. In Section 3, the design of robust H_∞ -based dynamic output feedback PSS controller is presented. The application results for a dynamic model of sixteen-machine, three-area test power system presented in Section 4. The conclusions are discussed in Section 5.

2. CONCEPT OF MODE SELECTIVE DAMPING

The controller can be described by the following equation:

$$U(s) = C(s)Y(s) \quad (1)$$

where $U(s)$ is the vector of control input signals for the whole system, $Y(s)$ contains the measured output signals available to the controller and $C(s)$ represents the controller transfer function. The complete multivariable controller of the type given in (1) is unwieldy and can not be implemented in the system for the practical use. Therefore, it is necessary to use a decomposition approach for the control task. This leads to the application of locally arranged decentralized PSS controllers. The idea of the decentralization concept is based on the following two-step decomposition strategy:

- (i) The supplementary remote input signals to the PSS controllers, selected from the whole system, and the local input signals to the PSS controllers should contain maximum information of the assigned inter-area mode. Generators, chosen as PSS controllers' actuators, should act in each case on the assigned mode effectively.
- (ii) Each of the local PSS controllers should work mainly in a frequency band given by the natural frequency of the assigned mode.

The decomposition strategy described above leads to a decentralized PSS controller structure in which each of the PSS controller systems, like the one in Fig. 3, has to be established separately for each of the inter-area modes of interest. Each designed PSS controller uses local and supplementary remote input signals in which a particular single inter-area mode is most observable and the designed PSS controller is located at a generator which is most effective in controlling the same single inter-area mode. Therefore, the controller transfer function matrix $C(s)$ in (1) attains a block diagonal structure:

$$C(s) = \text{diag} \{ C_{kk}(s) \} \quad (2)$$

Each of the PSS controllers belonging to a considered inter-area mode is to be interpreted as a central MIMO-type system, i.e., each controller sub-matrix C_{kk} is a full matrix.

The selection of suitable local and supplementary remote signals and locations for PSS controllers is done in the similar way given in (Hashmani and Erlich, 2010). An identification algorithm is applied to the measured frequency response data to obtain a linear dynamic model which accurately represents the system (Hashmani, 2010).

3. DESIGN OF PSS CONTROLLERS FOR POWER SYSTEMS

3.1 Problem Formulation

After augmenting the controller in the multi-machine power system, the overall extended system equations for the system can be rewritten in a compact form as follows (Hashmani and Erlich, 2008):

$$\dot{\tilde{\mathbf{x}}}(t) = \mathbf{A}_d \tilde{\mathbf{x}}(t) + \mathbf{B}_d \mathbf{w}(t) \quad (3)$$

$$\mathbf{z}(t) = \mathbf{C}_{cl} \tilde{\mathbf{x}}(t) + \mathbf{D}_{cl} \mathbf{w}(t) \quad (4)$$

where, $\tilde{\mathbf{x}}(t) = [\mathbf{x}^T(t) \quad \mathbf{x}_c^T(t)]^T$ is the augmented state vector for the closed-loop system, $\mathbf{x}(t)$ is the state vector of the open-loop system augmented by weighting functions, and $\mathbf{x}_c(t)$ is the state vector of the controller. The performance weighting functions are selected in such a way that the PSS controller belonging to a particular assigned single mode works mainly in the frequency band of that mode. In this way, separate damping of each mode becomes possible.

3.2 Robust H_∞ -based PSS Output Feedback Controller Design

Any general system interconnection can be put in the general linear fractional transformation (LFT) framework shown in Fig. 4, where $\mathbf{P}(s)$ is the generalized plant or interconnected system, $\mathbf{C}(s)$ is the controller. Designing an H_∞ controller for the system is equivalent to that of finding the controller matrix, in (3) and (4), that satisfies an H_∞ norm bound condition on the closed loop transfer functions $\mathbf{T}_{zw}(s) = \mathbf{C}_{cl}(sI - \mathbf{A}_{cl})^{-1}\mathbf{B}_{cl}$ from disturbance $\mathbf{w}(t)$ to the controlled outputs $\mathbf{z}(t)$ in Fig. 4, i.e., $\|\mathbf{T}_{zw}(s)\|_\infty < \gamma$ (for a given scalar constant $\gamma > 0$). Moreover, $\mathbf{T}_{zw}(s)$ must be stable (Gahinet and Apkarian, 1994). An algebraic Riccati equation (ARE) approach (Doyle et al., 1989) can be applied to establish the existence of control strategy that internally stabilizes $\mathbf{T}_{zw}(s)$ and satisfies a certain prescribed disturbance attenuation (or gain) level $\gamma > 0$ on $\mathbf{T}_{zw}(s)$, i.e., $\|\mathbf{T}_{zw}(s)\|_\infty < \gamma$.

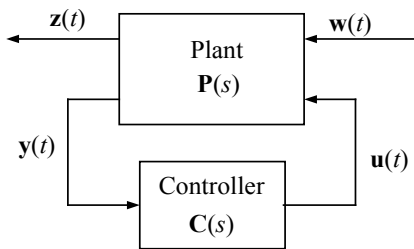

Fig. 4 General LFT framework representing general interconnected system

In this study, sequential design (Chiu et al., 1992), which is probably the most common and popular design method for decentralized control of real multivariable processes (Hovd et al., 1994), is used to design the proposed PSS controllers.

4. APPLICATION RESULTS

4.1 Power System Simulation Model

Sixteen-machine, three-area power system example, shown in Fig. 5, is selected to illustrate the effectiveness of the proposed robust H_∞ controller for a better damping of system oscillations. The test system consists of three strongly meshed areas, which are connected by long distance transmission lines. Therefore, the system experiences inter-area oscillations. The system has been developed based on characteristic parameters of the European interconnected electric power system, also known as UCTE/CENTREL (Teeuwssen et al., 2006). All generators are equipped with identical IEEE standard exciters (IEEE type DC1A excitation system). Moreover, for all simulation studies as well as for the PSS design, the structure of the i^{th} generator together with an n_{ci}^{th} -order PSS controller in a multi-machine power system given in (Hashmani and Erlich, 2008) is considered.

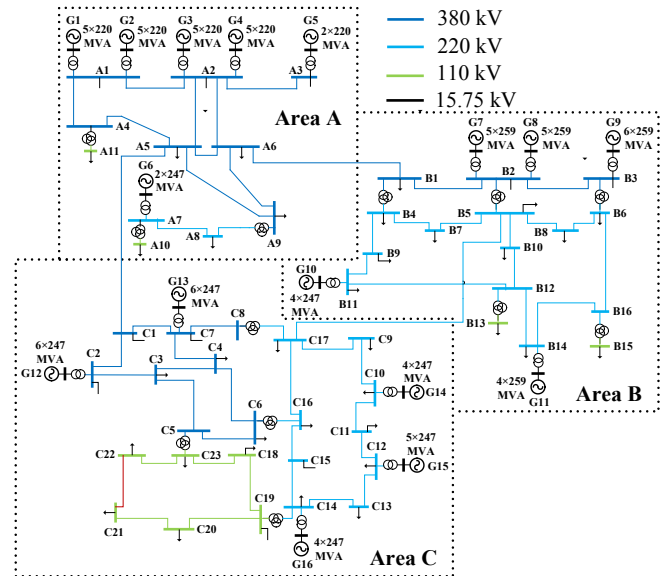

Fig. 5 One line diagram of a test sixteen-machine, three-area power system

For illustrative purposes and from a sensitivity study, the damping ratio (ζ) limit criterion for the test system, considered in this study, is defined as greater than 10% for all oscillatory modes and for all operating conditions. The profile of two most weakly damped rotor angle low-frequency electromechanical inter-area modes of oscillation, for the nominal power flow solution of the test system, is provided in Table I. As there are two weakly damped inter-area modes in the considered test system, therefore, the decomposition strategy described in Section 3 suggests that there will be two PSS controllers for the considered test system.

TABLE I: INTER-AREA MODES OF TEST SYSTEM

#	Inter-area Modes	ζ , %	Frequency, Hz
1	-0.0793+j3.8629	2.05	0.61
2	-0.5982+j5.7031	10.43	0.91

Table II summarizes the results for the selection of suitable local and remote input signals and locations of local decentralized PSS controllers, to be designed to damp out the two most weakly damped inter-area modes in the considered test system.

TABLE II: SELECTED SUITABLE LOCAL AND REMOTE SIGNALS AND LOCATIONS FOR PSS CONTROLLERS

Mode No.	Local Signals to Controllers	Remote Signals to Controllers	Locations of Controllers to be designed
1	P_{G15}	P_{B5C17}	Generator G15
2	P_{G4}	P_{A6B1}	Generator G4

4.2 Design Results

During the design of robust H_∞ -based PSS controller for the inter-area mode 1, P_{G15} and P_{B5C17} are used as its feedback input signals, i.e., $y(t) = [P_{G15}(t) \ P_{B5C17}(t)]^T$. The measured signals P_{G15} and P_{B5C17} , the output of the PSS together with the terminal voltage error signals, which are the inputs to the regulator of the exciter, are used as regulated signals within this design framework, i.e., $z(t) = [P_{G15}(t) \ P_{B5C17}(t) \ u_{s1}(t)]^T$. Similarly, during the design of robust H_∞ -based PSS controller for the inter-area mode 2, P_{G4} and P_{A6B1} are used as its feedback input signals, i.e., $y(t) = [P_{G4}(t) \ P_{A6B1}(t)]^T$. The measured signals P_3 and P_{57} , the output of the PSS together with the terminal voltage error signals, which are the inputs to the regulator of the exciter, are used as regulated signals within this design framework, i.e., $z(t) = [P_{G4}(t) \ P_{A6B1}(t) \ u_{s2}(t)]^T$. The design procedure described in Section 4 is used to design the controllers such that minimum disturbance attenuation (from $w(t)$ to $z(t)$) is achieved. In this study, balanced residualization technique (Skogestad and Postlethwaite, 2005) is used to reduce the order of controllers at each of the stages of design.

4.2.1 Sequential Design of PSS Controllers

As two PSS controllers need to be designed for the test system, the sequential design can, therefore, be performed in two different ways, depending on the sequence in which the controllers are designed. Table III provides description of the sequences for the design of controllers in the two possible sequential designs. Note that first control loop consists of plant and the PSS controller, designed for inter-area mode 1 without considering time delay and with considering time delay uncertainty in its remote input signal, located at G2 and the second control loop consists of plant and the PSS controller, designed for inter-area mode 2 without considering time delay and with considering time delay uncertainty in its remote input signal, located at G3.

4.2.1.1 First Sequential Design

Table IV provides the profile of two most weakly damped inter-area modes of the test system with the controllers

designed for inter-area modes 1 and 2 without considering time delay and with no delay in their remote input signals.

TABLE III: SEQUENCES FOR DESIGN OF CONTROLLERS IN TWO POSSIBLE SEQUENTIAL DESIGNS

#	Sequences for the Design of Controllers
1	(i) PSS controller for inter-area mode 1 is designed first without considering time delay and with considering time delay in its remote input signal and with keeping the second control loop open; (ii) PSS controller for the inter-area mode 2 is then designed without considering time delay and with considering time delay in its remote input signal and with keeping the first control loop closed, i.e., with already designed corresponding PSS controller for inter-area mode 1 located at generator G2 in the test system.;
2	(i) PSS controller for inter-area mode 2 is designed first without considering time delay and with considering time delay in its remote input signal and with keeping the first control loop open; (ii) PSS controller for the inter-area mode 1 is then designed without considering time delay in its remote input signal and with keeping the second control loop closed, i.e., with already designed corresponding PSS controller for inter-area mode 2 located at generator G4 in the test system.

Table IV also shows the profile of same inter-area modes with the controllers designed for inter-area modes 1 and 2 without considering time delay in their remote input signals but taking into account of 1000 ms delay in the simulation.

TABLE IV: INTER-AREA MODES IN TEST SYSTEM

Mode No.	Contr. designed for modes 1,2 without considering time delay; no delay added in input signals during simulation			Contr. designed for modes 1,2 without considering time delay; 1000 ms delay added in input signals during simulation		
	Inter-area Modes	ξ (%)	Freq. (Hz)	Inter-area Modes	ξ (%)	Freq. (Hz)
1	-1.4794+j3.4207	43.70	0.54	-0.3274+j3.2632	3.32	0.52
2	-1.2015+j5.0564	23.12	0.80	-0.4358+j4.8934	11.01	0.75

By considering that the uncertainty in the time delay in the remote input signal $P_{e1d}(t)$ of the PSS controller ranges from 0 ms to 1000 ms, the constants A_d , B_d , C_d , D_d for the uncertain time delay model (Hashmani and Erlich, 2009), thus, can be obtained as follows:

$$A_d = -6.3342, \ B_d = 13.1894, \ C_d = 1, \ D_d = -1$$

Reduced-order H_∞ -based PSS controller, thus, obtained is:

$$C_{11ud}(s) = \left[8.60 \frac{(1+s 0.3483)(1+s 0.2614)}{(1+s 0.5127)(1+s 0.6295)} \mid 20.1 \frac{(1+s 1.21)(1+s 0.82)}{(1+s 0.5127)(1+s 0.6295)} \right]$$

Here the index "ud" stands for uncertain delay. Table V shows the profile of two most weakly damped inter-area modes of the test system with the controller designed for inter-area mode 1 with considering time delay uncertainty in its remote input signals and with delay of 1000 ms in its remote input signal. The PSS controller for the inter-area mode 2 is now designed with keeping the first control loop closed, i.e., with the PSS controller already designed, with considering delay uncertainty in its remote input signal, for inter-area mode 1 located at generator G2 in the test system.

TABLE V: INTER-AREA MODES IN TEST SYSTEM

Mode No.	Controller designed for mode 1 by considering delay; 1000 ms delay added in remote input signals during simulation			Contr. designed for modes 1,2 with considering delay; 1000 ms delay added in input signals during simulation		
	Inter-area Modes	ξ (%)	Freq. (Hz)	Inter-area Modes	ξ (%)	Freq. (Hz)
1	-1.2434+j4.3132	30.12	0.69	-1.2494+j4.4213	31.02	0.71
2	-0.4359+j4.8934	11.56	0.75	-1.3528+j5.0914	34.71	0.81

The H_∞ -based PSS controller for the inter-area mode 2, with considering time delay uncertainty in its remote input signal, obtained is:

$$C_{22ud}(s) = \left[\begin{array}{c} 6.250 \frac{(1+s 0.5073)(1+s 0.1534)}{(1+s 0.1428)(1+s 0.9385)} \\ 16.17 \frac{(1+s 2.61)(1+s 0.73)}{(1+s 0.1428)(1+s 0.9385)} \end{array} \right]$$

Table V also provides the profile of two most weakly damped inter-area modes of the test system with the controllers designed for inter-area modes 1 and 2, by considering time delay uncertainty in their remote input signals and a delay of 1000 ms in their remote input signals.

4.2.1.2 Second Sequential Design

Table VI provides the profile of two most weakly damped inter-area modes of the test system with the controllers designed for inter-area modes 1 and 2, with considering time delay uncertainty in their remote input signals and with delay of 1000 ms in their remote input signals.

TABLE VI: INTER-AREA MODES IN TEST SYSTEM

Controllers designed for modes 1,2 with considering time delay; 1000 ms delay added in input signals during simulation		
Inter-area Modes	ξ (%)	Freq. (Hz)
-1.5241+j4.4652	39.62	0.72
-1.6458+j5.2431	40.31	0.84

Comparison of results for the first and second sequential designs indicate that the damping of inter-area modes 1 and 2 has increased more in second sequential design than in the first one. Therefore, it is concluded that second sequential design is better than the first one.

4.3 Time-Domain Simulation Results

In order to simulate the system behaviour under large disturbance conditions, a balanced three-phase fault is applied at bus A2, for the duration of 100 ms, in the test system.

4.3.1 Second Sequential Design of PSS Controllers

The behaviour of deviation of real power delivered by generator G3 ($\Delta P_{G3}(t)$) with the PSS controllers designed for the inter-area modes 1 and 2 without considering delay in their remote input signals and with no delay in their remote input signals, with the PSS controllers designed for the inter-area modes 1 and 2 without considering delay in their remote input signals and with 1000 ms delay in their remote input signals, and with the PSS controllers designed for the inter-

area modes 1 and 2 with considering delay uncertainty in their remote input signals and with 1000 ms delay in their remote input signals is shown in Fig. 9.

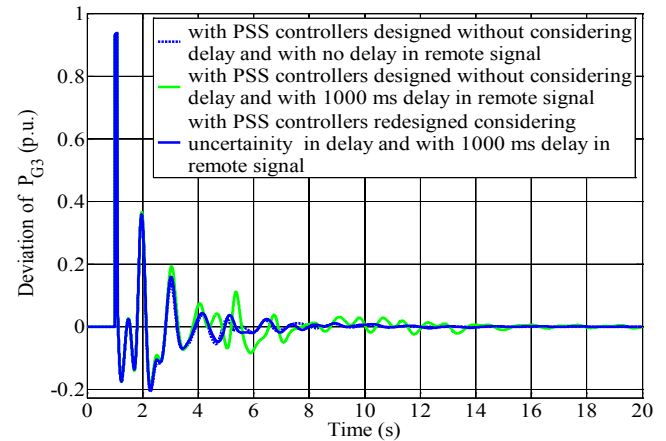

Fig. 9 Deviation of $P_{G3}(t)$ ($\Delta P_{G3}(t)$), following a three-phase fault at bus A2 in the test system

This figure indicates that the response of deviation of $\Delta P_{G3}(t)$, with PSS controllers designed for inter-area modes 1 and 2 without considering time delay, is better damped when no delay is included in the remote input signals of the controllers during the simulation but becomes oscillatory when a constant delay of 1000 ms is included in the remote input signals during the simulation. Fig. 9 also indicates that for a constant delay of 1000 ms included in the remote input signals during the simulation, the response of deviation of $\Delta P_{G3}(t)$, with H_∞ -based PSS controller redesigned considering uncertainty in delay, is better damped as compared to that with H_∞ -based PSS controller designed without considering delay.

5.4.2 Robustness of Controller Regarding Time Delay

To further assess effectiveness of the proposed approach regarding robustness, transient performance indices are computed for different time delays. Transient performance index for electrical power output of the generator, following a three-phase short-circuit of 100 ms duration at bus A2 in Fig. 5, is computed using the following equation:

$$I = \int_0^t |P_c(t) - P_{e0}(t)| dt \quad (7)$$

For comparison purpose, this index is normalized to the index for the mean value of delay range considered in the delay uncertainty case:

$$I_N = I_{DD} / I_{MD} \quad (8)$$

where I_{DD} is the transient performance index for different time delays and I_{MD} is the transient performance index for the mean value of delay range considered in the delay uncertainty case. The normalized transient performance indices for the electrical power output of the generator, for the time delays ranging from 0 to 1000 ms, with the proposed H_∞ -based PSS controller, designed considering uncertainty in time delay in its remote input signal and with the H_∞ -based PSS controller, designed without considering time delay in its remote input signal are shown in Fig. 10. It can be seen from the Fig. 10

that the normalized transient performance indices for the proposed PSS controller, are more near to unity, for the range of time delays for which the controller is designed, as compared to those for the PSS controller designed without considering time delay in its remote input signal.

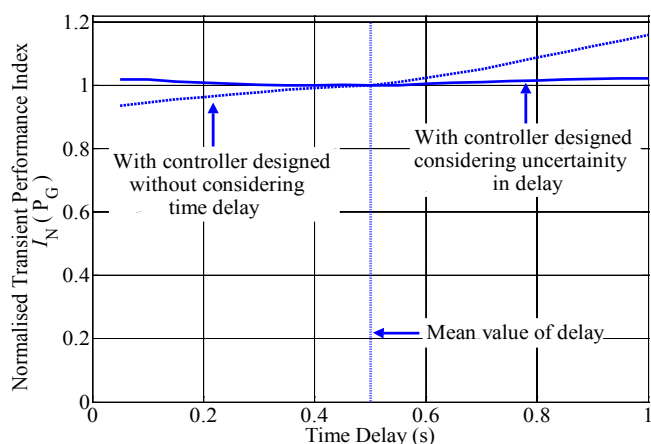

Fig. 10. Normalized transient performance index I_N for electrical power generated

This clearly indicates that, for different time delays, the transient responses of the generator with the proposed PSS controller, designed considering time delay uncertainty, are well damped as compared to those with the PSS controller, designed without considering time delay. This indicates that, the system behaviour exhibits robustness with the proposed controller for the range of time delays for which the controller is designed. This shows that the proposed PSS controller, designed considering time delay uncertainty, is more robust regarding time delay uncertainty as compared to the H_∞ -based PSS controller, designed without considering time delay.

5. CONCLUSIONS

The local decentralized control design approach for the separate damping of inter-area modes of interest, considering uncertainty in time delay in the remote signals, proposed in this paper, is applied on a sixteen-machine, three-area test power system. System identification technique is used for deriving lower order state-space models suitable for control design. Two local decentralized robust H_∞ -based PSS controllers have been designed for the two most weakly damped inter-area modes present in the test power system. PSS controller for an assigned single inter-area mode is designed first without and with considering uncertainty in time delay in its remote input signal and with keeping the other control loop open. PSS controller for the other assigned single inter-area mode is then designed without and with considering uncertainty in time delay in its remote input signal and with keeping the first control loop closed, i.e., with already designed corresponding PSS controller for the first assigned single inter-area mode located in the test system. Each of the two controllers, designed for the test power system uses only those local and remote feedback input signals in which the assigned inter-area mode is highly observable and is located at a generator which is highly

effective in controlling the same assigned inter-area mode. The two PSS controllers for the test power system are designed in such a way that each of them is effective only in a frequency band given by the natural frequency of the corresponding assigned mode. The two PSS controllers, therefore, damp only their corresponding assigned inter-area modes. The nonlinear simulation results show that the controllers, designed considering uncertainty in time delay, contribute significantly to the damping of inter-area oscillations and the enhancement of small-signal stability in presence of wide range of variations in time delay in the remote input signal of controllers.

REFERENCES

- Castro J. C. D. and Araujo C. S. D. (1998). Frequency domain analysis of oscillatory modes in decentralized control systems. *Automatica*, vol. 34, No. 12, pp. 1647-1649.
- Chiu M. S. and Arkun Y. (1992). A methodology for sequential design of robust decentralized control systems. *Automatica*, vol. 28, No. 5, pp. 997-1001.
- Doyle John C., Glover Keith, Khargonekar Pramod P., and Francis Bruce A. (1989). State-space solutions to standard H_2 and H_∞ control problems. *IEEE Transactions on Automatic Control*, vol. 34, No. 8, pp. 831-847.
- Gahinet P. and Apkarian P. (1994). A linear matrix inequality approach to H_∞ control. *International Journal of Robust and Nonlinear control*, vol. 4, pp. 421-448.
- Hashmani A. A., Erlich I. (2008). Power system stabilizer by using supplementary remote signals. *Proceedings of 16th PSCC*, Glasgow, paper No. 131.
- Hashmani A. A., Erlich I. (2009). Delayed-input power system stabilizer using supplementary remote signals. *Proceedings of International Federation of Automatic Control (IFAC) Symposium on Power Plants and Power Systems Control (PP & PSC)*, Tampere, Finland.
- Hashmani A. A., Erlich I. (2010). Mode selective damping of power system electromechanical oscillations using supplementary remote signals. *IET Generation, Transmission & Distribution*, UK, accepted for publication.
- Hashmani A. A. (2010). Damping of Electromechanical Oscillations in Power Systems using Wide Area Control. *Ph.D. Thesis, UniversityDuisburg-Essen*; CEA 294 T 622.
- Heydt G. T., Liu C. C., Phadke A. G., and Vittal V. (2001). Solutions for the crisis in electric power supply. *IEEE Computer Applications in Power*, pp. 22-30.
- Hovd M. and Skogestad S. (1994). Sequential design of decentralized controllers. *Automatica*, vol. 30, No. 10, pp. 1601-1607.
- Skogestad S. and Postlethwaite I. (2005). *Multivariable feedback control*, Wiley.
- Teeuwssen S. P., Erlich I., El-Sharkawi M. A. and Bachmann U. (2006). Genetic Algorithm and Decision Tree based Oscillatory Stability Assessment. *IEEE Transactions on Power Systems*, vol. 21, No. 2. pp. 746-753.