

Simulation of Microturbine Generation System Performance during Grid Faults under new Grid Code Requirements

M. Z. C. Wanik, *Graduate Student Member, IEEE*, and I. Erlich, *Senior Member, IEEE*

Abstract--New grid codes requires distributed energy resources to ride through temporary low voltage event and at the same time injecting reactive current into the grid. In microturbine generation system (MTGS) connected to the grid through power electronic converter, during low voltage ride through, its DC-link voltage increases and MTGS converter is overloaded. The paper discussed and highlights the problems and proposed solutions to mitigate these problems. The effectiveness of the solution is demonstrated using digital simulation. Result shows that MTGS is capable of riding through low voltage events while adhere to new grid code requirements without operating beyond its electrical components permissible limit.

Index Terms--Microturbine generation system, Distributed energy resources, Low voltage ride through, Grid codes.

I. NOMENCLATURE

$\underline{i}, \underline{u}$: Complex current and voltage
 l, x, r : Inductance, reactance, resistance
 $\underline{\psi}$: Complex flux-linkages
 ω : Angular speed
 t, T : Torque, time constant
 \cdot : Time derivative

Subscripts

d, q : Direct, quadrature axis component
 σ, h : Leakage and mutual
 D, f : Damping and field winding
 S, R : Stator and rotor

II. INTRODUCTION

BENEFITS offered by distribution generation (DG) concept supporting by conducive policies and regulations has increased the proliferation of distributed energy resources (DER) into low voltage (LV) electrical power system [1]. A few DER technologies such as microturbine generation system (MTGS), photovoltaic (PV), and fuel cell (FC) interfaces with the electrical grid through power electronic converters (PEC). There is also a trend now even to decouple internal combustion engine between the electrical grid using power

electronic converter for economic reasons [2].

Among converter based DER technologies, MTGS is gaining popularity due to proven economic reasons and environmental friendliness. Its overall efficiency could reach up to 85 % when operating this unit as a combine heat and power plant (CHP). In addition it has many advantages compared to other distributed generation technologies because of its low installation cost, low infrastructure requirement and low maintenance cost. This unit could be employed for providing base load power, utility peak shaving and customer peak shaving to name a few [3].

Due to its benefits and advantages, a numbers of MTGS units has been installed and operated throughout the world and the figure is steadily increasing [4]. This DER technology is expected to be seen in a substantial number operating inside low voltage (LV) level of electrical distribution network in the future.

A numbers of MTGS already has been installed in low voltage network for nearly a decade. This unit has been program to operate according to current utility requirements. The questions rise whether these units are able to meet new grid codes requirements and if required what necessary modification need to be made.

In [4], [5], [6] and [7] a single shaft MTGS dynamic model and its performance as a DER was described and presented. All these studies however are concentrating on load following capability. MTGS dynamic model and corresponding PEC controller presented in these studies however is not enough for low voltage ride through (LVRT).

During LVRT, the converter will be under stressed and DC-link voltage will increase. Controlling the unit to enable this fault ride through is more complicated thus requires some modification in the power converter controller. This paper identifies the problems and proposed counter measures to enable MTGS adhere to new grid requirements without damaging its hardware components.

III. GRID CODES AND INTERCONNECTION STANDARD

DER application changes the operational method of distribution system from passive to active. This reason has made many utilities placing stringent requirements for the DER connected to their distribution network. These requirements are different between one utility to another but some effort has been done to introduce a common standard such as IEEE Standard 1547 in the U.S [8]. This standard requires DER to stop energizing the power system when voltage level at PCC goes bellow 88% of nominal value. This

M. Z. C. Wanik is with Department of Electrical Power System, University of Duisburg Essen, Germany. (email: mohd.zamri@uni-due.de).

I. Erlich is with the Department of Electrical Power System, University of Duisburg Essen, Germany. (email: istvan.erlich@uni-due.de).

standard has been revised but still in drafting process and the new version is expected to be published soon.

During a momentarily grid faults, it is however been realised that it is a great loss to the power system to disconnect every DER if there are a large number of these generators operating in the system. Losses of this generators means a loss of active power and the system will face substantial active power shortage during this critical period. Furthermore if these DER remains in the system they could be used during disturbance to help stabilising the power system and providing voltage support.

Some of the utilities in the U.S. are however already introduced new grid codes which requires DER connected to LV to ride trough the grid faults less than specified time even if the voltage at PCC is reaching zero [9]. This new requirement is derived based on [8] and [10] with some modifications. Typical requirements for this fault ride through are depicted in fig. 1.

New grid codes in Germany already imposing new LVRT requirements for converter based generators connected to high voltage (HV) [11] and medium voltage (MV) [12] grid. Even though these two standards are for HV and MV, with some assumptions, the requirements could be applied for LV as

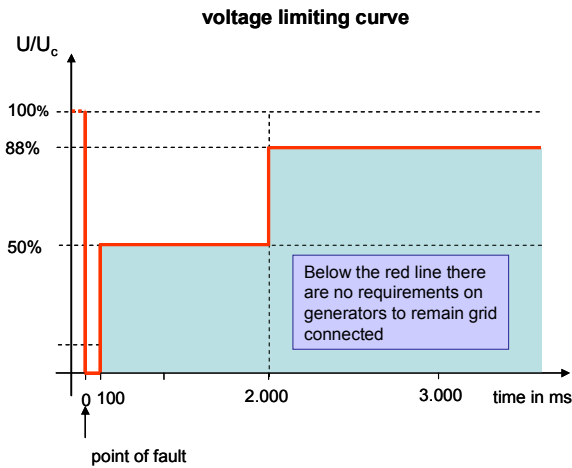

Fig. 1. CA21 fault ride through requirements [9]

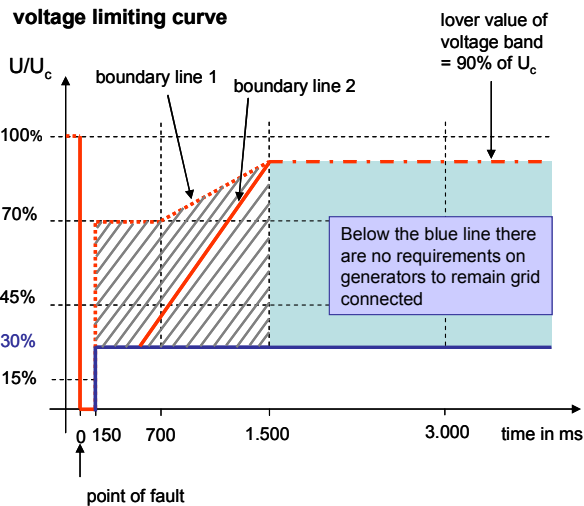

Fig. 2. Fault ride through requirement. [12]

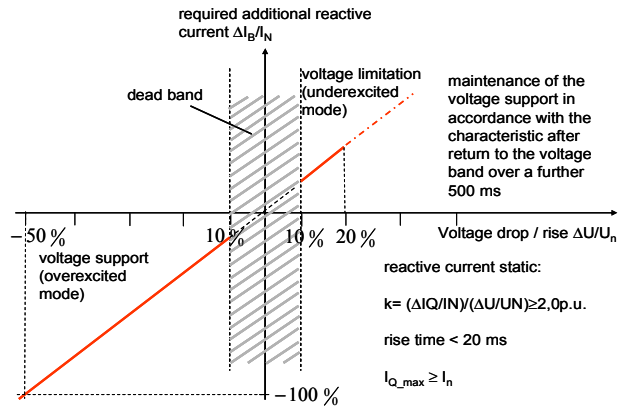

Fig. 3. Reactive current requirements [11]

well. The LVRT requirements imposed during grid faults from these two standards are quite similar and it is expected that a standard that will apply for LV will also having similar requirement in the future. Assuming this is the case, LVRT requirements from [12] are used in the study to simulate the performance of MTGS connected to LV bus during grid faults. These new requirement is depicted in fig. 2.

It is clear that, DER must ride through the faults that results in voltage drop at the point of connection which occur less than 150 ms. Further explanation of this requirement can be found in [11] and [12]. In this study however the main focus is given to the voltage abnormality within first 150 ms.

In addition to the LVRT requirements DER are also required to provide reactive current during fault to support grid voltage [11]. This voltage support requirement is considered in this study based on the requirement specified in [11] and is depicted in fig. 3. 100 % of capacitive reactive current must already be provided when the voltage drop to 50 % of its effective value.

IV. MICROTURBINE GENERATION SYSTEM TECHNOLOGY

MTGS is a small gas combustion engine producing power between 25 kW to 500 kW and operating at very high rotating

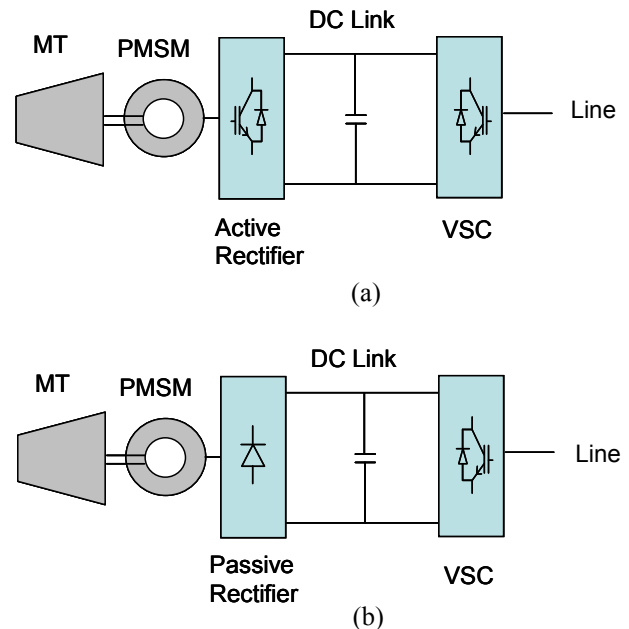

Fig. 4. MTGS hardware arrangement

speed which is between 50,000 to 120,000 rpm [13]. First type of MTGS has generator and turbine mounted on the same shaft thus generate power at a very high frequency. Therefore, interfacing with the grid is only possible through frequency converter. Second type of MTGS on the otherhand has generator and turbine mounted on different shaft. High rotational speed in the later case is reduced to synchronous speed through a gear box.

A single shaft design is more preferable compared to split shaft type due to less moving parts and thus requires less maintenance and the unit is also smaller. In a single shaft microturbine design, the main components are compressor, recuperator, combustion chamber and turbine. The compressor compresses ambient air and pushes it into the combustion chamber where it is mixed with the fuel and burned in continuous combustion process. The hot pressurized gas is then converted into mechanical energy through the turbines and in turn rotates the shaft where compressor and generator are mounted.

Most of commercially available MTGS are of single shaft design and use DC-link power converter topology [13]. Typical hardware arrangement of a single shaft design is depicted in fig. 4. Converting AC to DC is performed by either active or passive rectifier. DC to AC conversion is performed using voltage source converter (VSC).

The choice of using passive or active rectifier is depends on the expected task. For example, if MTGS will be used for shaving peak and only go online for a certain period in the day, regular start up is needed. In this case, IGBTs based active rectifier is employed which enabled bidirectional flow of power. During startup, the power is extracted from the grid to bring PMSM up to a certain speed before it can be operated as a generator. This eliminates the need for additional equipment for start up.

If MTGS is used to supply part of based load and is operated continuously, start up process could be only during initial commissioning and after major overhaul which is happen only once in a few years. In this case, diode rectifier for AC-DC conversion is employed.

Eventhough configuration in fig. 4 (a) offers more flexibility, most of commercial MTGS are constructed using configuration in fig. 4 (b) to lower its production cost and to reduce complexity [2].

VSC is normally employed self commutated devices controlled by pulse modulated circuit. Its circuit consists of six IGBTs and six anti parallel diodes. IGBTs are preferred because they allow more higher switching frequencies compared to others self commutated devices. For MTGS converter, switching frequency of up to 18 kHz is used which varies depending on its manufacturer [13].

Fundamental frequency line to line AC voltage and DC voltage of converter is related according to:

$$|u_{CON}| = m \frac{\sqrt{3}}{2\sqrt{2}} u_{dc} \quad (1)$$

A control variable here is its pulse-width modulation index m . This index is usually kept between $0 \leq m < 1$ because above this value, converter starts saturating and more low order harmonics begin to increase.

V. MICROTURBINE GENERATION SYSTEM MODELING

A. Microturbine

Microturbine system used in this study was based on gas turbine model presented in [14]. The model was successfully adopted for microturbine modeling by several authors [4], [5], [6] and [15]. As depicted in fig. 5, the model comprises of fuel control, turbine dynamic and speed governor. The main symbols in the figure are as follows:

K	: Gain of the speed governor
t_m	: Mechanical torque
w_F	: Fuel input signal
w_{MIN}	: Fuel demand at no load
ω, ω_{ref}	: Angular speed, angular speed reference
T_X	: Lead-time constant of speed governor
$T_Y, T_{VP}, T_{FS}, T_{CD}$: Lag-time constant of the speed governor, the valve positioner, the fuel system, and the compressor discharge respectively.

Speed controller works based on speed errors between reference speed and microturbine actual speed. Speed controller is modeled using lead lag transfer function. The output of the speed controller represent fuel signal for the turbine. The value of fuel signal is scaled by the gain value and then is offset by minimum fuel value at no load operation. A time delay associated with the fuel transportation through the turbines and combustion reaction are considered in the model by first order delay of valve positioner, fuel system and compressor discharge.

A mechanical torque of a single shaft microturbine is linear and is a function of fuel flow and turbine angular speed and is given by the following equation [14]

$$t_m = 1.3(w_F - w_{MIN}) + 0.5(1 - \omega) \quad (2)$$

The input to this dynamic equivalent is generator instantaneous speed, ω and the output is mechanical torque t_m to be fed to the generator.

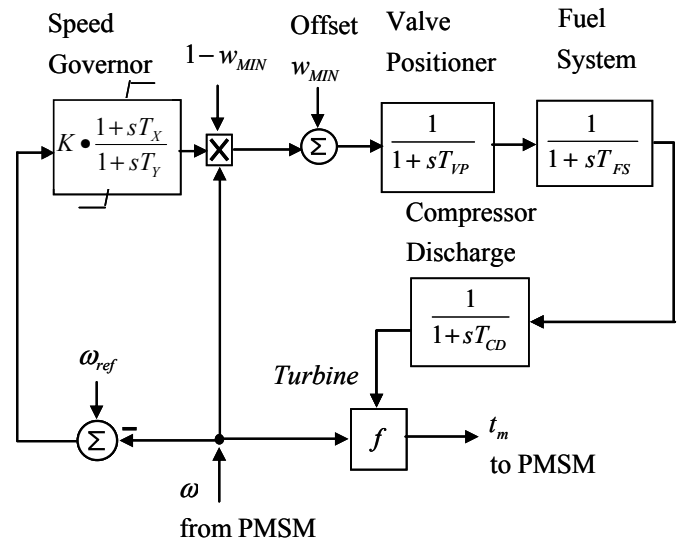

Fig. 5. Microturbine dynamic equivalent

B. PMSM

Microturbines drive usually permanent magnet synchronous machine (PMSM). PMSM model can be derived from full order model of synchronous machine (SM) by making field current constant. Assuming the winding is sinusoidal-distributed and by neglecting saturation, eddy currents and hysteresis losses, mathematical equations of SM for power system studies can be derived [16].

In dq rotor coordinate system, equivalent circuits of PMSM are depicted in fig. 6 and fig. 7 respectively. Referring to fig. 6 and fig. 7, stator voltage equations are:

$$u_d = r_s i_d - \omega \psi_q + \dot{\psi}_q \quad (3)$$

$$u_q = r_s i_q + \omega \psi_d + \dot{\psi}_d \quad (4)$$

The rotor voltage equations are:

$$0 = r_{Dd} i_{Dd} + \dot{\psi}_{Dd} \quad (5)$$

$$0 = r_{Dq} i_{Dq} + \dot{\psi}_{Dq} \quad (6)$$

Flux linkage is required to complete the PMSM model. Stator flux linkages are:

$$\psi_d = (l_{hd} + l_{\sigma s}) i_d + l_{hd} i_{fd0} + l_{hd} i_{Dd} \quad (7)$$

$$\psi_q = (l_{hq} + l_{\sigma s}) i_q + l_{hq} i_{Dq} \quad (8)$$

Rotor flux linkages are:

$$\psi_{Dd} = l_{hd} i_d + l_{hd} i_{fd0} + (l_{hd} + l_{\sigma Dd}) i_{Dd} \quad (9)$$

$$\psi_{Dq} = l_{hq} i_q + (l_{hq} + l_{\sigma Dq}) i_{Dq} \quad (10)$$

Electrical torque is given by

$$t_e = \psi_d i_q - \psi_q i_d \quad (11)$$

Equation of motion are given by

$$\dot{\omega}_R = \frac{1}{T_m} (t_e + t_m) \quad (12)$$

$$\dot{\delta}_R = \omega_R - \omega_0 \quad (13)$$

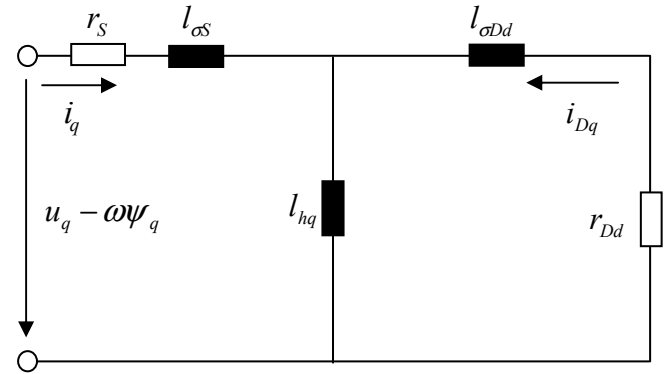

Fig. 7. q-axis PMSM model

T_m is mechanical starting time constant which is defined as a time required to accelerate the rotor from standstill to its rated speed. It is equivalent to per-unit inertia constant, H times two. In steady state no load operation the PMSM terminal voltage corresponds with

$$u_{d0} = 0 \quad (14)$$

$$u_{q0} = \omega l_{hd} i_{fd0} \quad (15)$$

C. Power Electronic Converter

Power converter topology depicted in fig. 4 (b) is employed in the model. VSC employing self commutated devices controlled by pulse modulated circuit with switching frequency of 15 kHz is used. Control variable m is kept below 1.1. For both diode rectifier and VSC, standard universal bridge block available in SimPowerSystem library [17] are used.

D. Power Electronic Controller

Most of major manufactures of MTGS claim that their units has digital control schemes controller and can be reprogram according to the grid requirement or customer need. In grid connected mode, MTGS is operated as a current source. The component to be controlled is its injected current to the grid. Converter controller for this mode is derived from the relationship between converter and grid voltage behind its inductor filter (refer fig. 8).

Defining currents flow into the converter and referring to synchronous reference frame, d and q component of grid voltages are

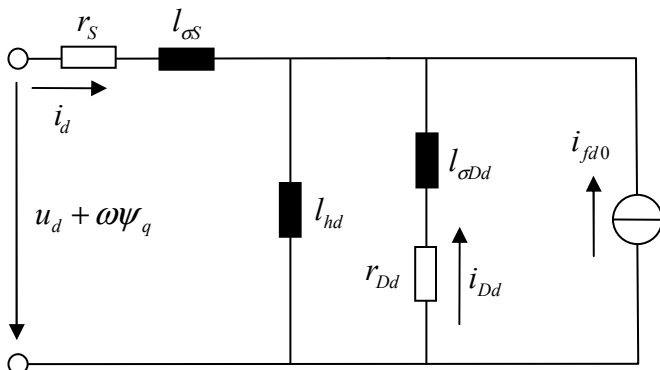

Fig. 6. d-axis PMSM model

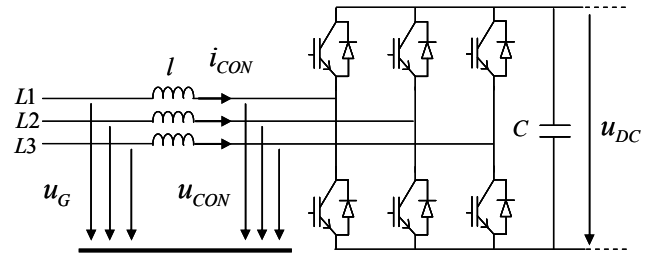

Fig. 8. Voltage source converter connected to the grid

$$u_{Gd} = l \frac{di_{CONd}}{dt} - \omega_0 l \cdot i_{CONq} + u_{CONd} \quad (16)$$

$$u_{Gq} = l \frac{di_{CONq}}{dt} + \omega_0 l \cdot i_{CONd} + u_{CONq} \quad (17)$$

For getting voltages of (16) and (17), controller must provide a reference voltage signal to converter. These voltage signals are

$$u_{CONd_ref} = -u'_{CONd} - \omega_0 l \cdot i_{CONq} + u_{Gd} \quad (18)$$

$$u_{CONq_ref} = -u'_{CONq} - \omega_0 l \cdot i_{CONd} + u_{Gq} \quad (19)$$

Where

$$u'_{CONd} = K_p \left(1 + \frac{1}{sT_I} \right) \cdot (i_{CONd_ref} - i_{CONd}) \quad (20)$$

$$u'_{CONq} = K_p \left(1 + \frac{1}{sT_I} \right) \cdot (i_{CONq_ref} - i_{CONq}) \quad (21)$$

are defined as current controller output. The current control loops derived are depicted in fig. 9. In a reference frame with orientation on the terminal voltage (d-axis always corresponds with the direction of terminal voltage) active power can be controlled by d-component of current and reactive part by its q-component.

During grid fault, MTGS terminal voltage drop below its rated value and active power injected into the grid is also dropping. PMSM is however not greatly affected and continue to deliver active power close to its setpoint value. In this period active power delivered by the generator through rectifier is higher than active power deliver by VSC into the grid. This unbalance results in DC overvoltage.

DC voltage has to be maintained close to nominal value during this fault ride through. To reduce DC voltage, the power inside DC circuit must be transfer as fast as possible to the electrical grid. Active current is therefore must always be guaranteed to be controlled to keep this DC voltage close to its nominal rated value. Active current control can be achieved by generating its reference value by DC voltage controller. For improving a dynamic of the converter during LVRT,

generated power from PMSM is feeding forward to the output of DC voltage controller.

As required by the new grid code requirement, negative reactive current need to be injected into the grid as well during this critical time according to the characteristic shown in fig. 3. Additional injected current into the grid means overloading the converter. The maximum current to be injected during LVRT must not exceed the permissible limit and has to be limited according to

$$|\dot{i}_{CON}| = \sqrt{i_{CONd}^2 + i_{CONq}^2} \leq i_{CONmax} \quad (22)$$

Magnitude of current permissible for MTGS converter is tabulated in table I [13]. Both active and reactive reference currents generation scheme is depicted graphically in fig. 10.

Even with the described converter controller, during LVRT, DC-link voltage could not be limited bellow 1.1 p.u. without large capacitance in its circuit. Large capacitance however means larger space needed to place the capacitor and this requires bigger space for MTGS unit's dimension. The solution to this problem is to add DC chopper inside DC-link. This chopper will dissipated the excess power during this critical period through its resistor. MTGS with this additional protection device is depicted in fig. 11.

TABLE I
MTGS CONVERTER PERMISSABLE OVERLOAD CURRENT [13]

Magnitude (%)	Time (ms)
300 %	40
200 %	1.000
150 %	10.000
125 %	30.000
110 %	60.000

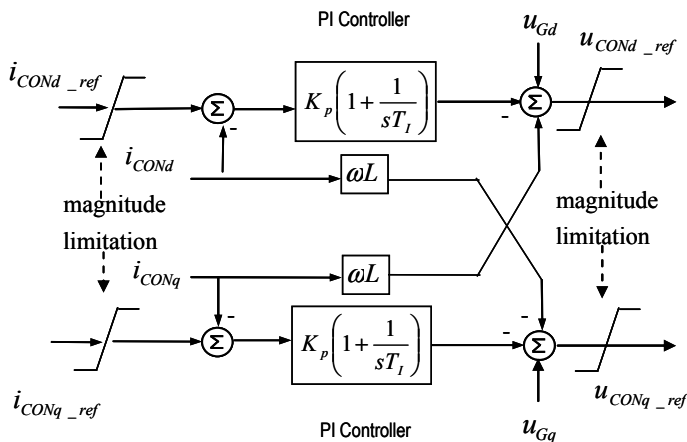

Fig. 9. Grid connected controller

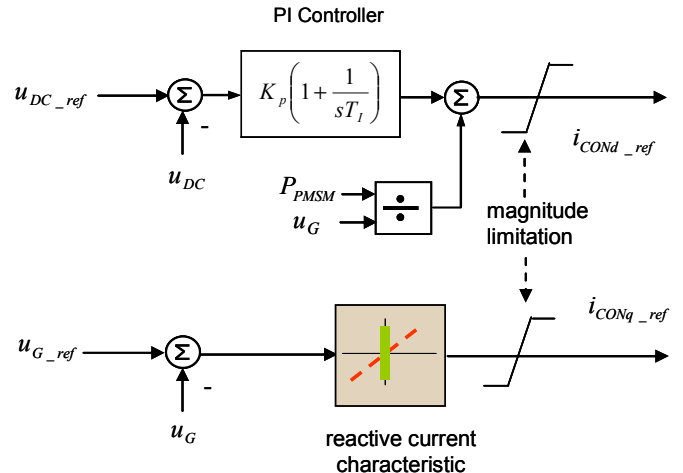

Fig. 10. Reference currents generation scheme

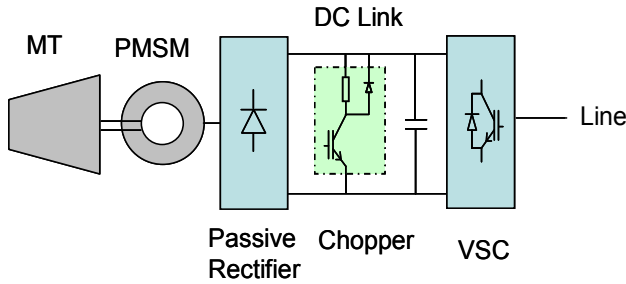

Fig. 11. MTGS with additional LVRT protection

VI. SIMULATION

All modeling and simulations are carried out in SimPowerSystem under MATLAB/Simulink environment [17]. It will be shown that without the present of DC chopper inside dc link circuit, LVRT causes DC voltage above its permissible value. 60 kW MTGS is modeled based on hardware arrangement shown in fig.4 (b). MTGS is connected to the 0.4 kV low voltage bus as shown in fig. 12 through an inductor filter. There is a local load connected to the same bus. Maximum active power delivered by MTGS when operating at rated value is 30 % of the total demand of the local load. During steady state operation, all active power from MTGS is consumed by the local load. There are two case scenarios simulated.

A. LVRT without chopper

MTGS is operating at its rated value in grid connected mode when there is a three phase balance fault inside HV network for 150 ms. This fault results about 50 % in magnitude of momentary voltage dip at the PCC node. As required by the new grid code, MTGS must ride through this magnitude of fault and at the same time supporting the grid with the required negative reactive current. Eventhough for this short duration overload, 200 % is permissible (refer table I), for providing safety margin, 1.5 p.u. is set as maximum converter current.

Fig. 13 depicted the respond of MTGS following previously mention voltage dip at PCC for 150 ms. Following the fault at $t = 0.5$ s, active power delivered by VSC reduces sharply due to drop in system voltage. Active power from PMSM through diode rectifier is however remain closed to set point value. This imbalance caused dc overvoltage and during this time converter controller try to increase active power injected to the grid by increasing active current. The priority however during this event is to provide negative reactive current which can be seen about 1 p.u. injected into the grid. Active current also injected into the grid during this critical time but subjected to equation (22). The total current as can be seen is limited to 1.5 p.u.

Even though active current is about 1 p.u., active power injected is only about 0.5 p.u. due to low voltage magnitude. Reactive power however increases up to 0.5 p.u. during this low voltage event.

When fault is cleared at $t = 0.65$ s, grid voltage return to nominal value but DC voltage still above its nominal value because there is still imbalance of power transfer inside its

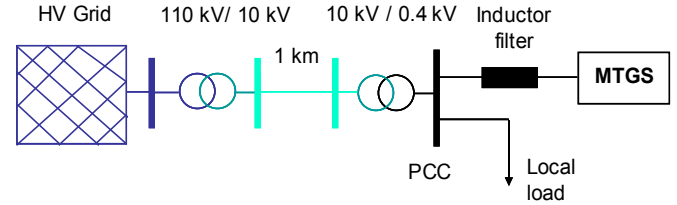

Fig. 12. Test grid

circuit. During this time priority is to provide active current until the balance between power transfer in power converter is reached which indicated by DC voltage return to its nominal value. Reactive current immediately reduces to zero after faults is cleared.

During the disturbance MTGS is under stress because it has to be operating beyond its nominal operating point. Total current delivered during and immediately after fault is above 1 p.u. of rated value continuously for about 200 ms. 150 % overloaded is however still within the converter permissible

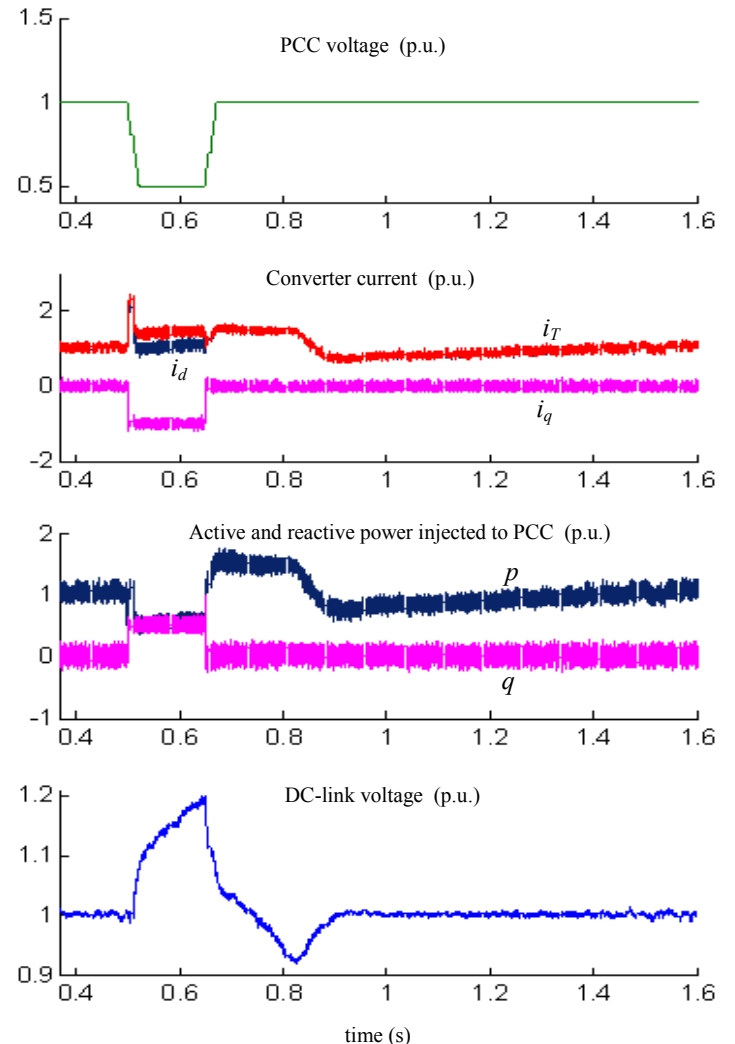

Fig. 13. LVRT without DC chopper

limit as 1 second is permissible for this magnitude as listed in table I. DC voltage however rises above nearly 1.2 p.u. and this is not acceptable. In the next simulation case, chopper will be embedded in the DC circuit to limit its voltage to 1.1 p.u.

B. LVRT with chopper

In second case, the same scenario as case one is simulated but MTGS is equipped with DC chopper inside its DC-link circuit. The result of simulation is depicted in fig. 14. Current injected and power supplied into the grid are quite similar as depicted in fig. 14 but overload time experience by the converter is shorter. DC voltage is also successfully limited below 1.1 p.u.

In both cases it can be seen there are current transients in the converter current with the peak of about 2.5 p.u for about 10 ms at the beginning of low voltage event. For this magnitude with the duration less than 40 ms, referring to table I, is still within the capability of MTGS converter.

The simulation results been discussed so far concentrating on electrical component of MTGS. It is also of interest to know the stress experience by the microturbine shaft. The rotational speeds of the shaft during simulated time are shown in fig. 15. During steady state, generator is operating at 1.06 p.u. of rated speed. During the low voltage event due to imbalance in electromagnetic torque and mechanical torque, generator rotor accelerates. Without chopper embedded inside DC-link circuit, maximum speed reaching nearly 1.2 p.u. of rated speed. Maximum speed with the chopper however close to 1.1 p.u. It is demonstrated that addition of protection device inside DC-link not only reduces the stress subjected to MTGS electrical components but also on its generator shaft.

VII. CONCLUSION

This paper describes an investigation study of capability of MTGS operating under new grid codes and respective simulation results have been presented. During LVRT, MTGS has to operate beyond its rated value for a short moment and this cause stress on its hardware components. These overstress can be limited within MTGS permissible overload operating limit with the use of controller presented coordinated with DC chopper inside its DC circuit. MTGS is also had been shown capable of supporting the grid with capacitive reactive current as required by the new grid code with the suggested controller. The question whether MTGS which already been installed in the power system capable of meeting a new grid code depends on its design and embraced technology. Assuming its PEC controller is programmable and DC protection devices is already equipped or easily added if absent, LVRT with the magnitude simulated and necessity to inject negative reactive current during this critical period can be managed by MTGS.

VIII. REFERENCES

- [1] H. B. Puttgen, P. R. Mac Gregor, and F. C. Lambert, "Distributed generation: semantic hype or dawn of a new era?", *IEEE Power & Energy Magazine*, vol. 1, no. 1, pp. 22-29, Jan./Feb. 2003.
- [2] W.Kramer, S. Chakraborty, B. Kroposki and H. Thomas, "Advanced power electronic interfaces for distributed energy systems - part 1: system and topologies," National Renewable Energy Laboratory, Golden, Colorado, Tech. Rep. NREL/TP-581-42672, Mar.2008.
- [3] Capstone Turbine Corporation, <http://www.capstoneturbine.com>

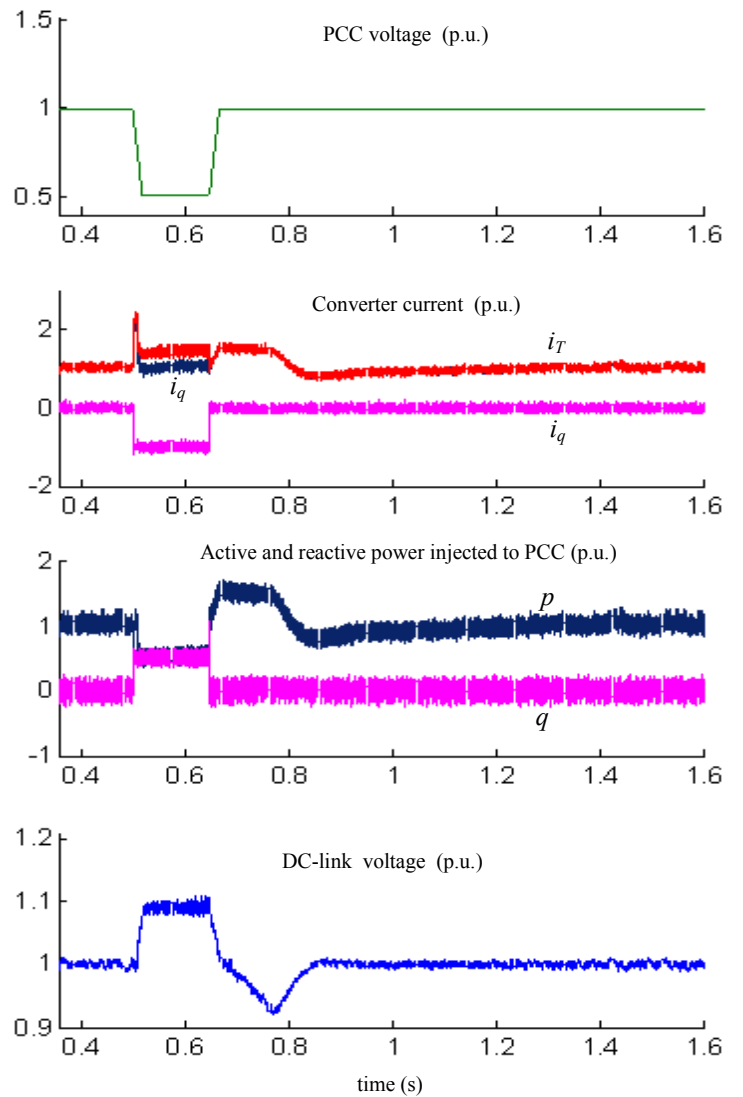

Fig. 14. LVRT with DC chopper

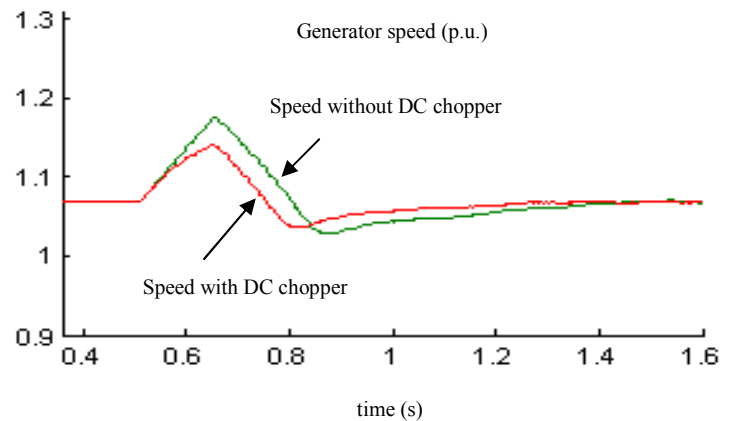

Fig. 15. PMSG generator rotational speed

- [4] S.R. Guda, C. Wang, M. H. Nehrir, "Modeling of microturbine power generation systems," *Electrical Power Component and Systems*, Vol. 34, No. 9, pp:1027-1041, Sept. 2006
- [5] D. N. Gaonkar, R. N. Patel, and G. N. Pillai, "Dynamic model of microturbine generation system for grid connected/islanding operation", in Proc. 2006 IEEE International Conference on Industrial Technology, pp: 305-310.
- [6] G. Bertani, C. Bossi, F. Fornari, S. Massucco, S. Spelta, and F. Tivegna, "A microturbine generation system for grid connected and islanding operation," in Proc. 2004 IEEE PES Power System Conference and Composition, pp. 360-365.
- [7] A.K. Saha, S. Chowdry, S. P. Chowdhury, P. A. Crossley, "Modeling and simulation of microturbine in islanded and grid-connected mode as distributed energy resource," in Proc. 2008 IEEE PES General Meeting.
- [8] IEEE Standard for Interconnecting Distributed Resources with Electrical Power Systems, IEEE Std. 1547, 2003
- [9] California Interconnection Guidebook. Sept. 2003. [online]. Available: http://www.energy.ca.gov/distgen/interconnection/guide_book.html
- [10] UL 1741, Standard for inverters, converters, and controllers for use in Independent Power Systems, 1999.
- [11] E.ON Netz GmbH, Byayreuth, Grid Code, High and Extra high voltage. [online]. Available. <http://www.eon-netz.com/Ressources/downloads/ENENARHS2006eng.pdf>
- [12] Technische richtlinie erzeugungsanlagen am mittelspannungsnetz, BDEW Standard. [online]. Available : http://www.energiesdienst.de/site/DE/netze/img/Pdf_02_netzanschluss/Technische_Richtlinien/BDEW_RL_EA-am-MS-Netz_Juni_2008.pdf
- [13] R.H. Staunton and B. Ozpineci, "Microturbine power conversion technology review," Oak Ridge National Laboratory, Washington, DC, Tech. Rep. ORNL/TM-2003/74, Apr. 2003.
- [14] W. I. Rowen, "Simplified mathematical representation of heavy duty gas turbines," *ASME Trans. Journal of Engineering for Power*, vol. 105, no. 4, pp. 865-869. Oct. 1983.
- [15] M. Z. C. Wanik and I. Erlich, "Dynamic simulation of microturbine distributed generators interconnected into multi-machines power system network," in Proc. 2008 IEEE International Conference on Power and Energy, pp. 1545-1550.
- [16] P. Kundur "Power System Stability and Control", McGraw-Hill, Inc., 1994.
- [17] MATLAB/SIMULINK SimPowerSystem Documentation. [online]. Available :<http://www.mathworks.com>

IX. BIOGRAPHIES



M. Z. C. Wanik (SM' 01 M' 03 GSM'08) received his BSc in Electrical Engineering from University of Evansville, USA in 1997 and MEngSc in Electrical Utility Engineering from Curtin University of Technology, Australia, in 2002. From 1997 to 2000 he was an engineer at Sony Technology (M) Sdn. Bhd. He joined Universiti Kebangsaan Malaysia in 2000 and presently is a lecturer at the same University. Since

2006 he is pursuing his PhD degree in the Department of Electrical Power System at the University-Duisburg-Essen, Germany. His current research interest is modeling and simulation of distributed resources integration to power system. He is a graduate student member of IEEE.



Istvan Erlich (1953) received his Dipl.-Ing. degree in electrical engineering from the University of Dresden/Germany in 1976. After his studies, he worked in Hungary in the field of electrical distribution networks. From 1979 to 1991, he joined the Department of Electrical Power Systems of the University of Dresden again, where he received his PhD degree in 1983. In the period of 1991 to

1998, he worked with the consulting company EAB in Berlin and the Fraunhofer Institute IITB Dresden respectively. During this time, he also had a teaching assignment at the University of Dresden. Since 1998, he is Professor and head of the Department of Electrical Power Systems at the University of Duisburg-Essen, Germany. His major scientific interest is focused on power system stability and control, modelling and simulation of power system dynamics including intelligent system applications. He is a member of VDE and a senior member of IEEE.