

Reactive Power Generation by DFIG Based Wind Farms with AC Grid Connection

I. Erlich, M. Wilch and C. Feltes
UNIVERSITY DUISBURG-ESSEN
Bismarckstr. 81
D-47057 Duisburg
Tel.: +49 / (203) – 379 3437
Fax: +49 / (203) – 379 2749
E-Mail: istvan.erlich@uni-due.de
URL: <http://www.uni-duisburg.de/fb9/ean>

Keywords

«Wind Energy, Doubly Fed Induction Motor, Transmission of Electrical Energy, Fault Handling Strategy, Energy System Management»

Abstract

Balancing reactive power within a grid is one of the fundamental tasks of transmission system operators. With increasing portion of wind power, wind turbines have to contribute to reactive power generation during steady state as well as during transient conditions. First, this paper provides an overview about the available options to supply reactive power by wind farms typically connected to the grid by AC cables. Then the Fault-ride Through (FRT) sequence of the Doubly-Fed Induction Generators (DFIG) is discussed in order to explain the reactive power generation capability of this type of wind turbines during low voltage periods. Under steady state conditions the utilization of var sources represents an optimization task. It is shown in the paper that generation of reactive power by WT may be a favorable option under economic aspects. FRT with DFIG is possible even if the grid voltage drops to zero. To protect the converter against overcurrent and overvoltage DFIG are equipped with crowbar and sometimes with chopper. When the crowbar is switched on the machine is a var consumer. However the Line Side Converter (LSC) can be controlled to supply up to 50% of the required reactive current. When the crowbar is not activated the DFIG can supply reactive power from the rotor side through the machine as well as through the LSC. For illustration, simulation results for an exemplary fault are shown and elucidated.

Introduction

Wind energy is the fastest growing power generation technology in the world. According to [1], the worldwide installed capacity reached 59,084 MW in 2005 and 74,223 MW in 2006. In Germany, the installed capacity of wind energy converters added up to 20,622MW with 18,685 wind turbines at the end of 2006 [2]. Germany experiences the second highest growth rate (behind the United States), but the number of newly installed wind turbines in onshore sites has declined in the past two years. According to a study of the German Energy Agency [3], the expected increase in onshore installed capacity will be achieved by retrofitting, which means the exchange of old turbines by new ones with taller towers and thus higher rated power. However, the main part of the upcoming increase will take place offshore where large wind farms are already under construction. Most of these wind farms will be connected to the 400-kV-grid via 150-kV-AC submarine cables. According to the German grid code wind farms have to supply not only active power but also reactive power into the grid. The requirements with respect to power factor are defined as a function of voltage at the point of common coupling (PCC) with the grid.

Under normal operating conditions, all available sources of reactive power should be deployed in an optimum way. Usually, this optimum entails the minimization of power losses in the transmission system or wind farm while meeting other requirements such as grid codes, etc. Possible sources of

reactive power in an offshore wind farm are capacitor banks as well as switchable reactors, flexible AC transmission devices (FACTS) and the wind turbines themselves. Beyond these, it is possible to influence the reactive power of a wind farm indirectly by using on-load tap changers.

Depending on the project considered, it may be desirable to switch off cables during distinct low load periods, if the transmission system provides alternative routes. This non-linear optimization task contains both continuous and discrete variables. In [4], the authors proposed to use particle swarm optimization to solve this problem.

Large offshore wind farms with several hundred Megawatt rated power will be connected directly to the high and extra high voltage grid. In Germany, transmission system operators have to provide grid connections for offshore wind farms. They are expected to use AC-connections as long as it is possible.

Two aspects arise from this assumption: First, offshore wind farms will have to supply reactive power during steady state to meet specific requirements at a defined point. The other aspect is that faults, regardless of their location in the grid or within the wind farm, will directly affect the wind turbines. In such cases, the grid code requires wind turbines to remain connected to the grid and provide voltage support by supplying reactive current. In other words, they have to behave in a similar manner to conventional power plants equipped with synchronous machines.

Steady state operation

Large offshore wind farms have to fulfill the same requirements as existing large power plants. These requirements are defined in grid codes, which every grid utility can modify individually. Depending on the structure of the grid, transmission system operators (TSO) change the desired power factor range for different voltages. Fig. 1 shows two examples of power factor requirements of two different TSOs. Operating points may be scheduled or set online.

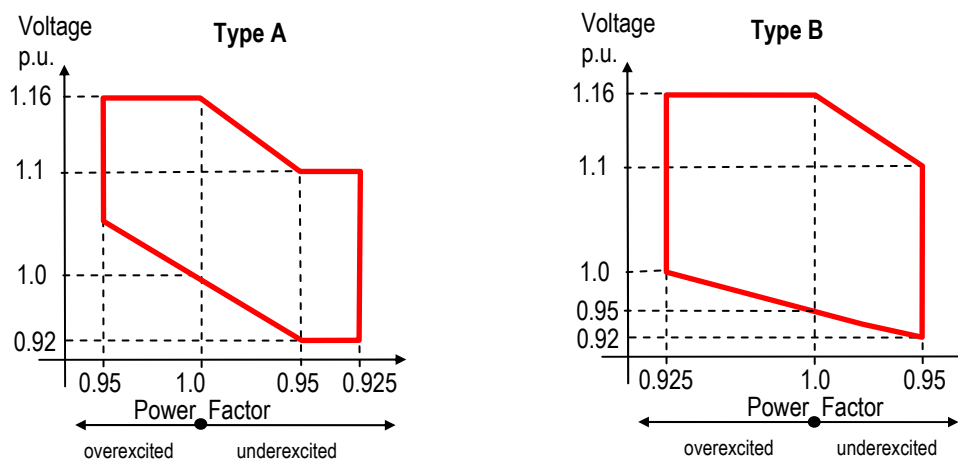

Fig. 1. Power-factor requirements of two different TSOs for generating units connected to the high voltage grid

The requirements have to be fulfilled at the PCC, which offers several options to provide the desired power factor. A typical layout of an offshore wind farm is shown in Fig. 2, where also some examples of reactive power sources are indicated, which will be discussed in the following section.

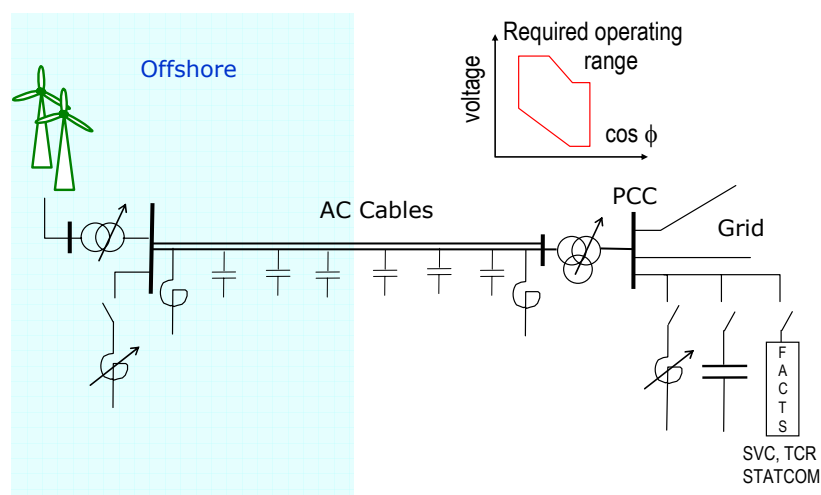

Fig. 2. Alternatives for reactive power generation

a) Cables

The cable used for grid connection is a source of reactive power. It can provide a substantial contribution to reactive power generation depending on the degree of compensation.

b) Transformers equipped with on-load tap changers

By using tap changers the voltage on the wind farm side can be controlled within the available range. As a consequence the charging reactive power of the cable including that of the shunt reactors will also be controlled. Furthermore, it is possible to reduce the reactive power demand by operating the system at lower voltage levels.

c) Shunt reactors and capacitors

Shunt reactors are widely used to compensate long cable lines. For this purpose, they are permanently connected to the cable. But besides this, they can also be used as an element in reactive power dispatch, then preferably connected at the PCC. To use switched shunt capacitors, additional transformers are necessary to provide a lower voltage level, since capacitors are not suitable for operation at high voltages.

d) FACTS

Many utilities hesitate to install FACTS-devices into their grid due to expected high costs. Typical shunt FACTS-devices are SVC or STATCOM. They offer the advantage of providing smooth variation of reactive power. Another advantage is the option to provide voltage support during transient conditions.

e) Wind turbines

Variable speed wind turbines are equipped with voltage source converters (VSC). Focusing on the converter, two types of turbines have to be distinguished: full converter machines and doubly-fed induction machines. For the former, the converter must be designed for the full rated power of the machine, and for the latter, the converter has to provide only up to one third of the rated power. This paper focuses on the doubly-fed induction machine (DFIM). A typical layout is shown in Fig. 3. The stator of a DFIM is directly connected to the grid while the rotor winding is supplied through VSC. By varying frequency and magnitude of the rotor voltage the generated active and reactive power can be controlled independently of each other. Active power control allows adapting rotor speed to the actual wind speed so that the maximum wind power utilization is achieved.

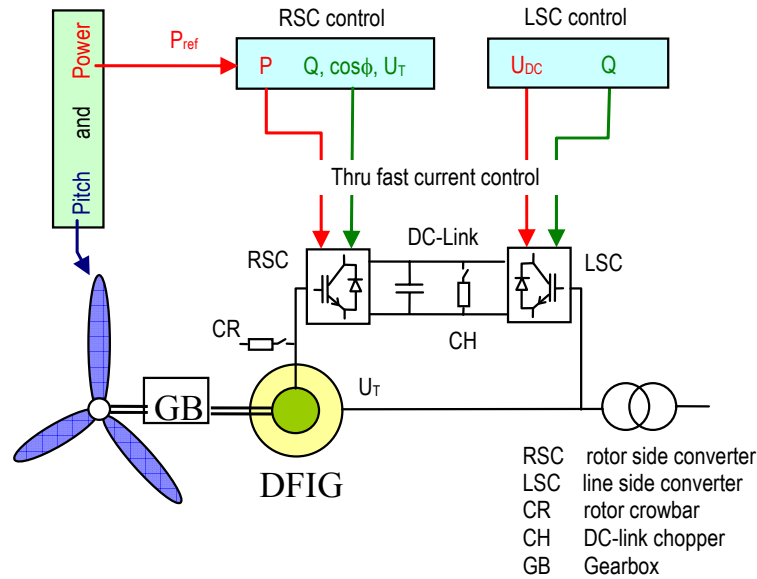

Fig. 3. Typical layout of a DFIG

The DFIG brings the advantage of utilizing the turns ratio of the machine, so the converter does not need to be rated for the machine’s full rated power. The rotor side converter (RSC) usually provides active and reactive power control of the machine while the line-side converter (LSC) keeps the voltage of the DC-link constant. The additional freedom of reactive power generation by the LSC is usually not used due to the fact that it is more preferable to do so using the RSC. However, within the available current capacity the LSC can be controlled to participate in reactive power generation in steady state as well as during low voltage periods. The LSC can supply the required reactive current very quickly while the RSC passes the current through the machine resulting in a delay. Both converters can be temporarily overloaded, so the DFIG is able to provide a considerable contribution to grid voltage support during short circuit periods.

Manufacturers offer different options for var generation by DFIG based wind turbines in steady state. Fig. 4 shows an example of two active power versus reactive power characteristics according to [5].

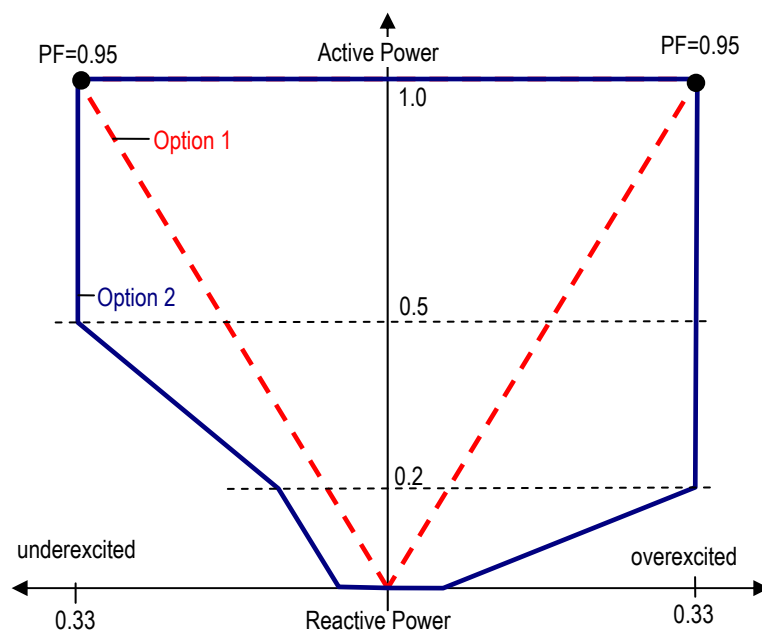

Fig. 4 Reactive power characteristics of DFIG base wind turbines [5]

The option to be implemented depends on the particular location of the wind turbine within the grid. Currently interest is focused on the extension of the reactive power generation range by a better utilization of the reactive power capability of the DFIG. As indicated in Fig. 4 DFIG based wind turbines can supply reactive power even at zero active power. One of the alternatives for extension of reactive power generation is to use the LSC which can also be operated as a STATCOM.

The distribution of reactive power generation between the available var sources including wind turbines represents an optimization task. When wind farms are connected to the grid through long submarine cables the utilization of wind turbines for reactive power generation seems to be not a favorable option due to the losses along the cable. In fact this is a trade-off between the losses on the one side and the costs for additional var source installation near the PCC on the other. It should also be considered that wind turbines are able to control reactive power continuously similar to voltage control, if required.

As an example Fig. 5 shows the transmission losses of a 400 MW offshore wind farm connected to the grid via two 150 kV submarine cables. The losses for all operating points are minimized by optimal settings of the tap changers located on the grid side as well as on the wind farm platform. Maximum losses are expected when the reactive power is generated only by wind turbines. Losses will be lower when additional var sources are utilized on the grid side. However, as shown in Fig. 5, it can be further reduced when both PCC reactive sources as well as wind turbines are used for reactive power generation. The differences between the three alternatives tend to get smaller with increasing active power transmission.

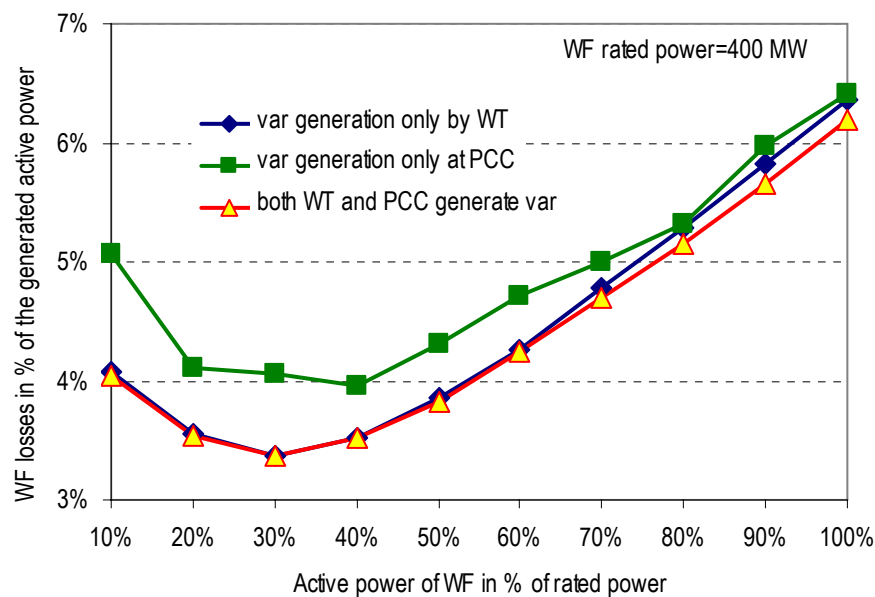

Fig. 5 Wind farm losses in relation to generated active power [6]

Reactive power generation during faults

Grid code requirements

In the past wind turbines were separated from the grid following grid faults. However, as of now, separation of wind turbines for voltage values below 80% of the nominal voltage are deemed to lead to loss of an undesirable portion of power generation. Therefore, according to the new E.on (one of the major utilities in Germany) grid code [7] utilities require a fault-ride-through (FRT) capability as specified in Fig. 6 [7]. Wind turbines must stay connected even when the voltage at the PCC drops to zero. The 150 ms delay shown in the figure accounts for the normal operating time of protection

relays. The red solid line in Fig. 6 marks the lower voltage boundary rather than any characteristic voltage behavior. According to [7] short term interruption (STI) is allowed under specific circumstances. STI in area 3 requires resynchronization within 2 s and a power increase rate of at least 10% of the nominal power per second. In area 2 the interruption time allowed is much less, just a few hundred milliseconds. Besides, reactive power supply by wind turbines is a requirement during this period. According to the German grid code wind turbines have to provide a mandatory voltage support during voltage dips. The corresponding voltage control characteristics are summarized in Fig 7. Accordingly wind turbines have to supply at least 1.0 p.u. reactive current already when the voltage falls below 50%. A dead band of 10% is introduced to avoid undesirable control actions. However, for wind farms connected to the high voltage grid continuous voltage control without dead band is also under consideration.

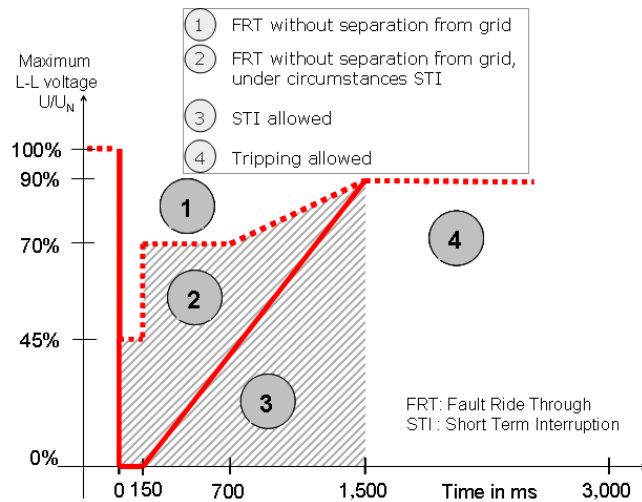

Fig. 6 FRT requirements according to the German E.on Grid Code

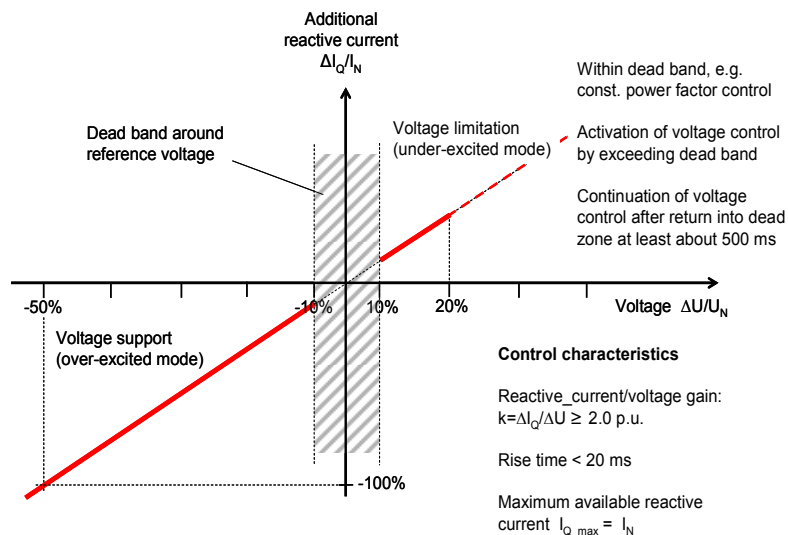

Fig. 7 Characteristic of voltage support according to the German E.on Grid Code

Fault ride through by DFIG

Riding through grid faults with DFIG may cause high stress for the IGBT converter due to the DC components of the stator short circuit currents, which also appear in the rotor circuit as AC components. These are superimposed on the steady-state rotor currents, leading to high peak currents

and thus high power flow into the DC circuit. Since IGBT semiconductors are very sensitive to overload and since the DC circuit can only sustain a limited DC voltage, additional protection measures are required. The DFIG system shown in Fig. 8 is extended for improved fault ride-through capability [8].

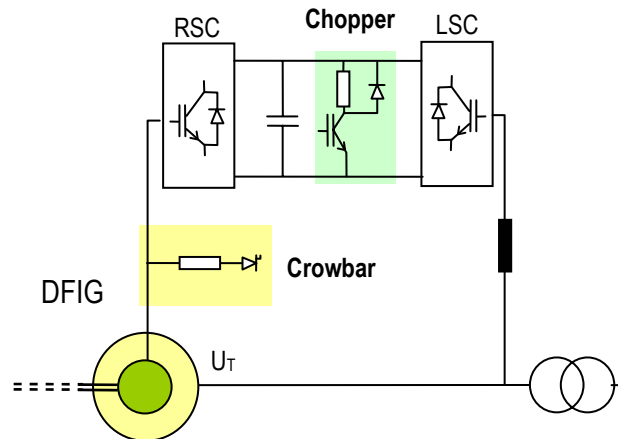

Fig. 8 Characteristic DFIG base system extended by FRT protection devices

It contains two protection circuits, a DC-chopper and an AC-crowbar to avoid DC-link over-voltages during grid faults. The chopper module is not essential for fault ride-through operation but it increases the normal range of DFIG operation by smoothing the DC-link voltage during heavy imbalances of active power on rotor- and line-side converter. Theoretically converters and choppers could be designed to withstand even terminal short-circuits but economic considerations normally limit to a lower rating.

Following deep voltage sags caused by grid short circuits the rotor currents and thus the RSC currents rise rapidly. The DC short circuit component on the stator side appears on the rotor side as an alternating current with high initial peak. When the current exceeds a certain limit the IGBTs will be stopped to protect the converter but the current and thus the energy continues to flow into the DC-link through the freewheeling diodes leading to fast voltage increase. To keep the DC voltage below the upper threshold first the chopper is switched on by IGBT switches. Depending on the level of energy flow into the DC link and the chopper design this measure may be successful in most cases. When the DC voltage is maintained by the chopper the RSC goes back into operation following a few milliseconds and the DFIG can be controlled again even if it is operating on a low voltage level. However, in extreme situations the DC voltage may increase further. As the next line of protection the crowbar is fired and the rotor is short-circuited. The crowbar firing is triggered by the DC-voltage. The characteristic operating modes of the RSC and the crowbar during FRT are shown in Fig. 9. When the crowbar is switched on the wind turbine operates as a slip-ring asynchronous machine. After a short transient period the machine becomes a reactive power consumer which is counterproductive in respect of the grid voltage support as required by the grid codes. However, the crowbar is switched on only for a time period of 60-120 ms. Because the crowbar thyristor switches used in many applications will not interrupt the currents before their zero-crossing, the exact interruption time is not predictable. Therefore, between crowbar interruption and RSC resynchronisation a possible time slot with open rotor circuits characterised as mode 3 in Fig.9 can exist.

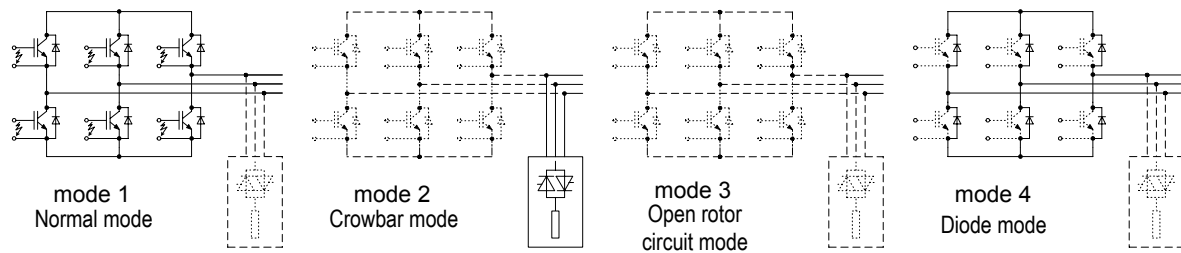

Fig. 9 Operation modes of the DFIG converter during FRT

When the converter is started again the DFIG can provide reactive power support to the grid and thus help stabilizing the grid voltage. During FRT the limitation of the RSC reference currents is switched from active current priority to reactive current priority. As a result the active power will be reduced automatically when the magnitude of the converter current reaches its threshold. The maximum current allowed for short time is usually approximately the steady state nominal current and adapted to the loading conditions of the semiconductors dynamically.

Additionally, the RSC and the LSC can also be used for reactive current supply. For this temporary overloading of LSC during FRT is possible so that 30-50% of the required 1.0 p.u. reactive current, according to the German grid code, can usually be supplied by the LSC. However, the primary task of LSC comprises the control of DC link voltage which is performed by the active current control loop. Therefore, the active current has always priority when the magnitude of the LSC reference current has to be limited.

Simulation results shown in this paper were computed using Matlab with SimPowerSystems Toolbox. For the DFIG, the model described in [8] was used. A simple one machine test network, basically consisting of the machine model, a short line, transformers and the Thevenin equivalent of the grid was implemented. The structure is shown in Fig. 10. The voltage sag or the severity of the fault could be influenced by the choice of the fault impedance.

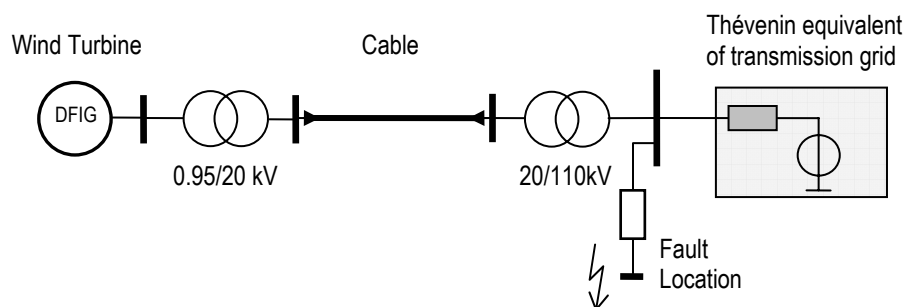

Fig. 10 Test network used for simulation (results in Fig. 11)

In Fig. 11 the characteristic behaviour of the DFIG is shown for a deep voltage sag. Immediately after the short circuit the DC-voltage rises to about the threshold value of 1.1 p.u., despite the intervention of the chopper. Then the crowbar is switched on and the RSC is separated from the DFIG. After 120 ms the RSC is re-synchronized and the wind turbine starts to supply active and reactive currents to the grid although the grid fault is still not cleared. To avoid overload, the rotor current limiter with priority on reactive current is active during this period. Following voltage recovery the system experiences a similar disturbance as at the beginning of the fault. However, in this case the DC-link voltage is kept within limit by the chopper so that the crowbar is not needed for a second time. As can be seen from the results the RSC has been successfully protected against the overload during the grid fault.

During FRT the voltage support through reactive current is shared between the machine stator and the LSC. When the fault occurs and the voltage decreases under a certain level (typically 85%-90%), the

LSC tries to support all the reactive current required by Fig. 7. In the simulation case presented here the voltage drops to approx. 20%, which means a total reactive current of at least 100% of the machine's rated current. The LSC current is limited to 50% with active current priority, so the rest has to be delivered through the machine stator, which is controlled by the RSC. But during crowbar period, the RSC is blocked and the stator reactive current can not be controlled. Furthermore, the generator acts as a conventional asynchronous machine, since the rotor windings are short-circuited through the crowbar-resistors. During this time, the generator is a reactive power consumer and the reactive power supplied by the LSC is mainly used for its compensation. This means a violation of the grid code requirements with regard to voltage support, but exceptions are made for this crowbar period, because it is essential for the protection of the converter. When the crowbar is switched off, the RSC remains blocked for a short while and is reconnected to the rotor 120ms after crowbar ignition. Then, the DFIG is fully controllable again and capable of supplying the reactive currents required or even more. Since a second crowbar ignition upon voltage return is prevented by the chopper, this period is uncritical concerning reactive power support.

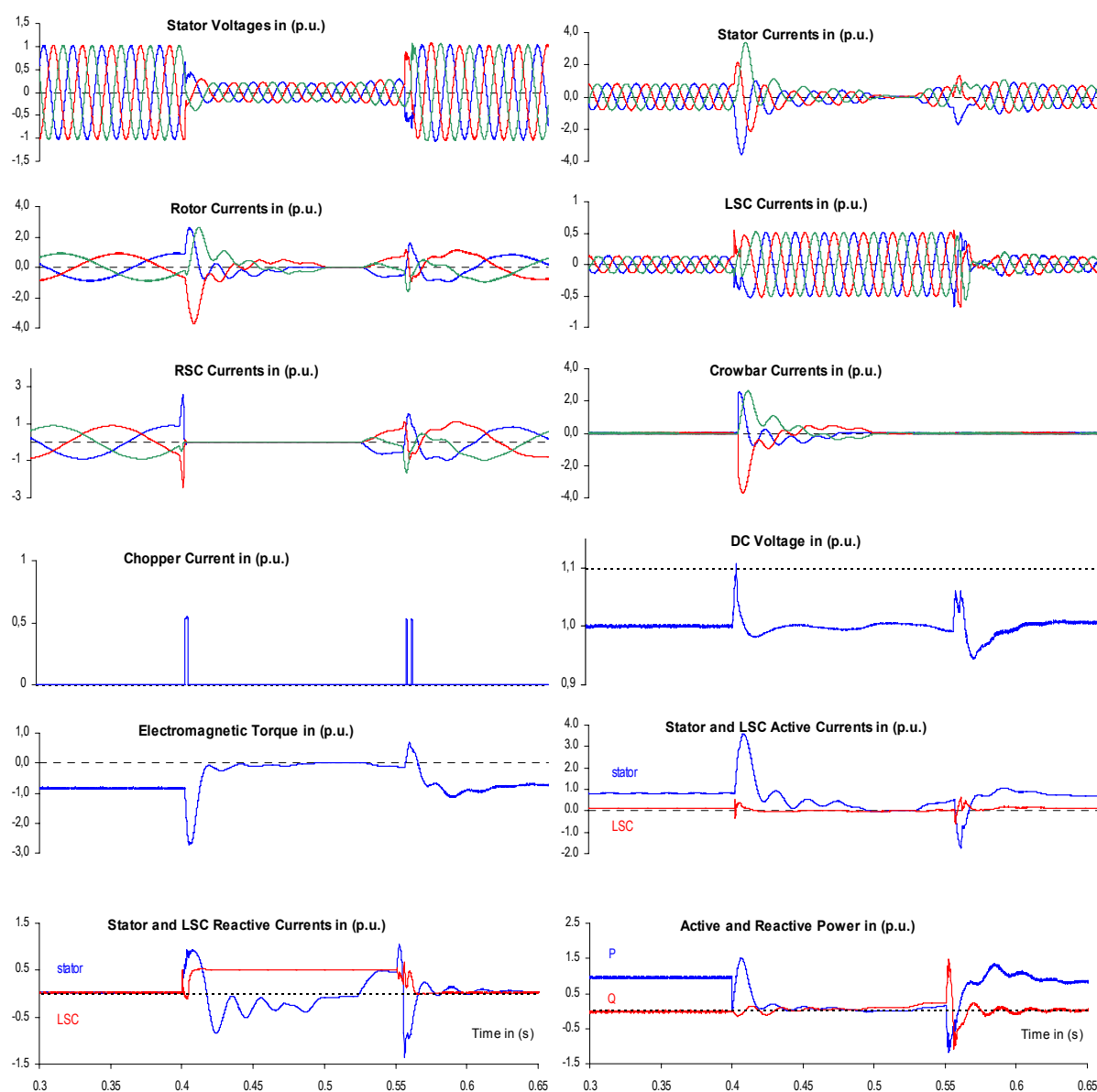

Fig. 11 Simulation results of DFIG with extended FRT capability during grid fault

Conclusion

In Germany, the installed wind turbine capacity has reached a level where wind turbines have to take part in reactive power dispatch and thus act like a conventional power plant. It was presented that using an optimization algorithm to manage the reactive power generation inside a wind farm, considerable savings can be achieved. Thus, it is recommended to integrate an optimization algorithm like the proposed adaptive particle swarm algorithm in the wind farm control structure.

It has been shown how a DFIG is able to ride through grid disturbances and support voltage by feeding in reactive current. Measures taken by manufacturers have been presented and discussed. It was clearly identified that the machine is not able to fulfill the grid code requirements when the crowbar is switched on. However, with stronger chopper and properly designed control it is possible to reduce the occurrence of events leading to crowbar firing considerably.

References

- [1] GWEC: Global Wind Energy Outlook 2006, <http://www.gwec.net>
- [2] BWE: statistics (Statistiken), in German, <http://www.wind-energie.de/de/statistiken>
- [3] DENA: Planning of the grid integration of wind energy in Germany onshore and offshore up to the year 2020 (dena grid study), http://www.offshorewind.de/media/article005857/dena_Grid_Study_Summary_2005-03-23.pdf
- [4] Pappala V. S., Wilch M., Singh S.N. and Erlich I.: Reactive power management in Offshore Wind Farms by Adaptive PSO, ISAP 2007
- [5] Repower Systems: Electrical Description REpower 5M (Elektrische Beschreibung REpower 5M), in German, REpower Systems, Rendsburg 2006
- [6] Wilch M., Pappala V. S., Singh S.N. and Erlich I.: Reactive Power Generation by DFIG Based Wind Farms with AC Grid Connection, IEEE PowerTech 2007
- [7] Erlich I., Winter W., Dittrich A.: Advanced Grid Requirements for the Integration of Wind Turbines into the German Transmission System, IEEE-PES General Meeting 2006, panel paper 06GM0837
- [8] Erlich I., Wrede H., Feltes C.: Dynamic Behaviour of DFIG-based Wind Turbines during Grid Faults, IEEE PCC Nagoya 2007, invited paper LS4-7-1