

Diplomarbeit: Broadband Matching of Patch- Array Antenna

Presented by
Wu,Liangjun

Supervisor
Prof. -Dr. - Ing. K. Solbach

Duisburg
18. 05. 2009

1. Introduction

The *microstrip antennas* have the advantages that they are compact in size, light in weight, low to cost and easy to fabricate. Despite these advantages they exhibit *an inherently narrow bandwidth*.

In this thesis a new *resonant matching circuit* to improve the bandwidth of the patch antenna is investigated.

And the concept of the resonant matching network for single antenna can be translated to the resonant matching network for *patch-array antenna*.

Finally a complete patch antenna array with feed network to improve the bandwidth at 10GHz is designed. The simulation results of this antenna array are demonstrated. The *matching bandwidth* and the *radiation pattern* of the experimental antenna array are tested.

2. Microstrip Antenna

2.1 Transmission-Line Model

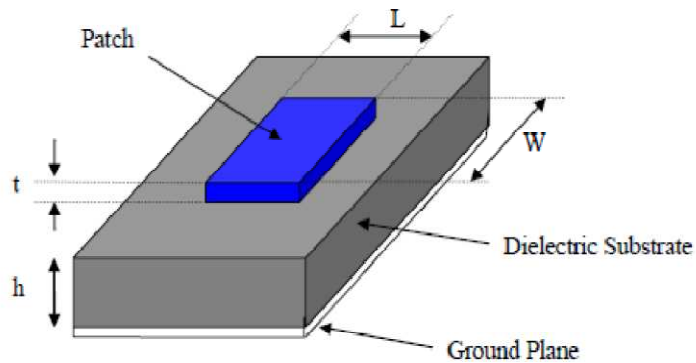

Basic structure of a microstrip antenna

Fringing Effekt

$$L_{\text{eff}} = L + 2 \Delta L$$

L : physical Length

L_{eff} : effektive Length

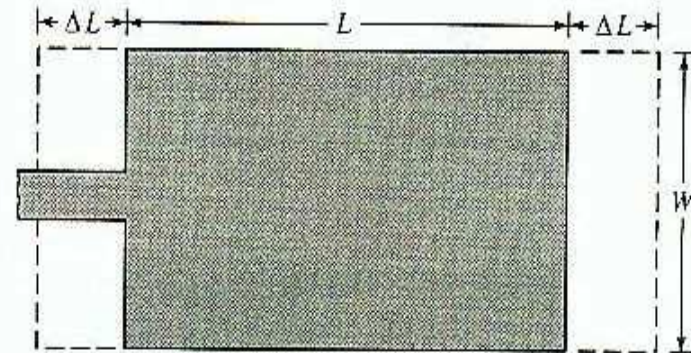

(a) Top view

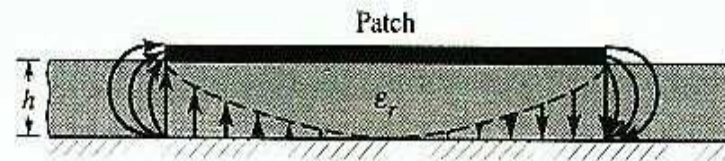

(b) Side view

$$\epsilon_{\text{reff}} = \frac{\epsilon_r + 1}{2} + \frac{\epsilon_r - 1}{2} \left[1 + 12 \frac{h}{W} \right]^{-1/2}$$

$$\frac{\Delta L}{h} = 0.412 \frac{(\epsilon_{\text{reff}} + 0.3) \left(\frac{W}{h} + 0.264 \right)}{(\epsilon_{\text{reff}} - 0.258) \left(\frac{W}{h} + 0.8 \right)}$$

$$L = L_{\text{eff}} - 2 \Delta L$$

$$L_{\text{eff}} = \frac{\lambda_{\text{eff}}}{2} = \frac{1}{2} \frac{C_0}{fr \sqrt{\epsilon_{\text{reff}}}}$$

h: Thickness of Substrate W: Width of Patch fr: Resonant Frequency

2.2 Patch-Antenna Design procedure

a) The substrate we use in Simulation is RT_DURROID_5880 ,with

$$\epsilon_r=2.2, h=0.79\text{mm}(35\mu\text{m Cooper}), \tan\delta= 0.002$$

b) For an efficient radiator, we let

$$W = \frac{v_0}{2fr} \sqrt{\frac{2}{\epsilon_r + 1}} = \frac{3 \times 10^8}{2(10 \times 10^9)} \sqrt{\frac{2}{2.2 + 1}} = 11.86\text{mm}$$

c) Using Transmission-Line Model, we have

$$\epsilon_{\text{reff}} = \frac{2.2 + 1}{2} + \frac{2.2 - 1}{2} \left[1 + 12 \frac{0.79}{11.86} \right]^{-1/2} = 2.08$$

$$\Delta L = 0.51(0.412) \frac{(2.2 + 0.3) \left(\frac{11.86}{0.79} + 0.264 \right)}{(2.2 - 0.258) \left(\frac{11.86}{0.79} + 0.8 \right)} = 0.4\text{mm}$$

$$L_{\text{eff}} = \frac{\lambda}{2} = \frac{1}{2} \frac{3 \times 10^8}{10 \times 10^9 \sqrt{2.08}} = 10.11\text{mm}$$

$$L = 10.11 - 2 \times 0.4 = 9.31\text{mm}$$

d) Microstrip-Line inset-length

From literature, we can approximately have y_0 for characteristic

impedance 50 ohm

$$y_0 = \frac{L}{2\sqrt{\epsilon_{reff}}} = \frac{9.31}{2\sqrt{2.08}} = 3.23 \text{ mm}$$

Let $Wf = 2.408 \text{ mm}$

(microstrip line width for 50 Ohm)

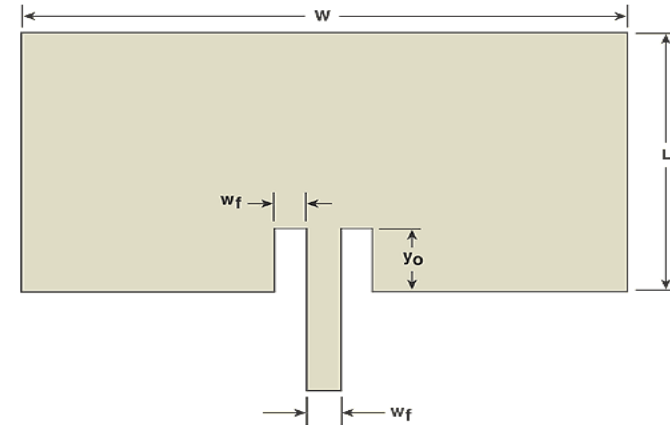

Also from (<http://mwrf.com/Articles/Index.cfm?ArticleID=6993>) we can get the exact inset length for 50 Ohm input impedance through the mathematical model

$$y_0 = 10^{-4} \{0.001699\epsilon_r^7 + 0.1376\epsilon_r^6 - 6.1783\epsilon_r^5 + 93.187\epsilon_r^4 - 682.69\epsilon_r^3 + 2561.9\epsilon_r^2 - 4043\epsilon_r + 6697\} \frac{L}{2} \quad 2 \leq \epsilon_r \leq 10$$

We have $y_0 = 2.24 \text{ mm}$

2.3 Simulation of the patch antenna

From 2.2 we have $W=11.86\text{mm}$, $L=9.31\text{mm}$, $wf=2.408\text{mm}$, $y_0=2.24\text{mm}$ for the antenna.

Using ADS---Momentum, we draw the antenna and have the Simulation result :

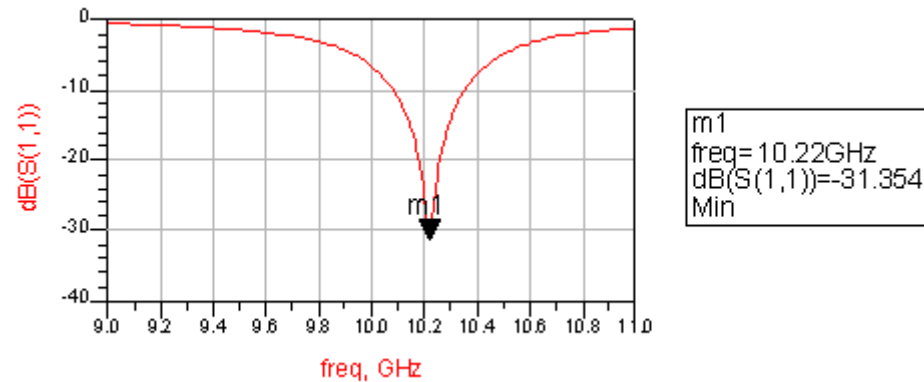

Then we change the $L=10.25\text{mm}$ to get $f_r=10\text{GHz}$. At the same time, we must change $y_0=2.47\text{mm}$. And the simulation result is:

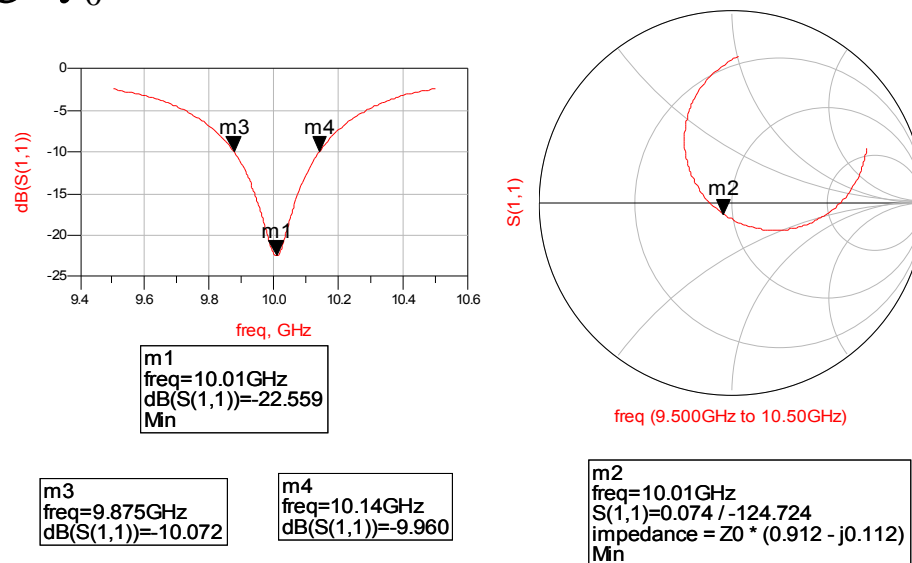

Finally we have $W=11.86\text{mm}$, $L=10.25\text{mm}$, $y_0=2.47\text{mm}$. And the bandwidth (at -10dB) of the antenna is approximately $BW=265\text{MHz}$ (2.65%).

3. Single LC-Resonator Matching Technique (SRMT)

Here the basic idea of SRMT will be introduced

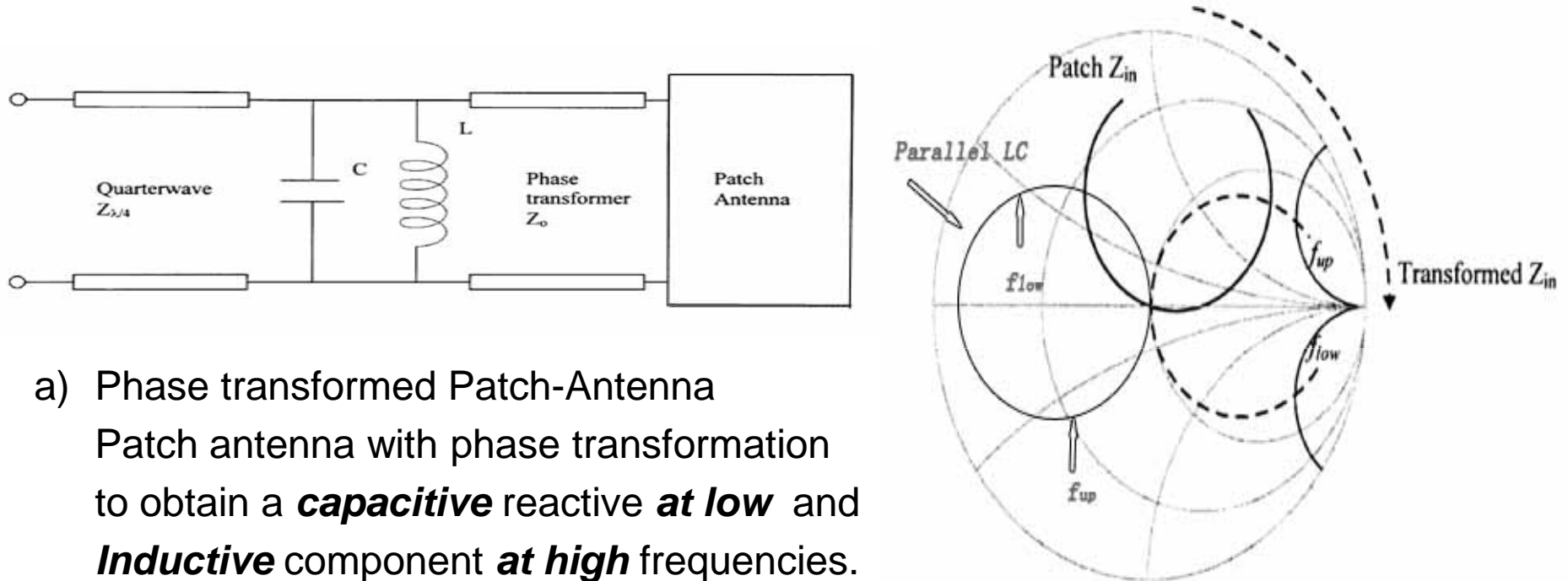

- a) Phase transformed Patch-Antenna
Patch antenna with phase transformation to obtain a **capacitive** reactive **at low** and **Inductive** component **at high** frequencies.

- b) Parallel LC-circuit
A parallel LC-circuit is exactly **capacitive at high** frequencies and **inductive at low** frequencies , where high and low are defined relative to the resonant frequency. This means the LC-circuit is **inverse** to the phase transformed patch antenna . When a suitable L, C are chosen, it can **cancel** some of the **imaginary parts** of the **patch antenna impedance**.

c) A phase transformed patch antenna with a matching parallel LC-circuit is given **in a literature** and its simulation result is also given

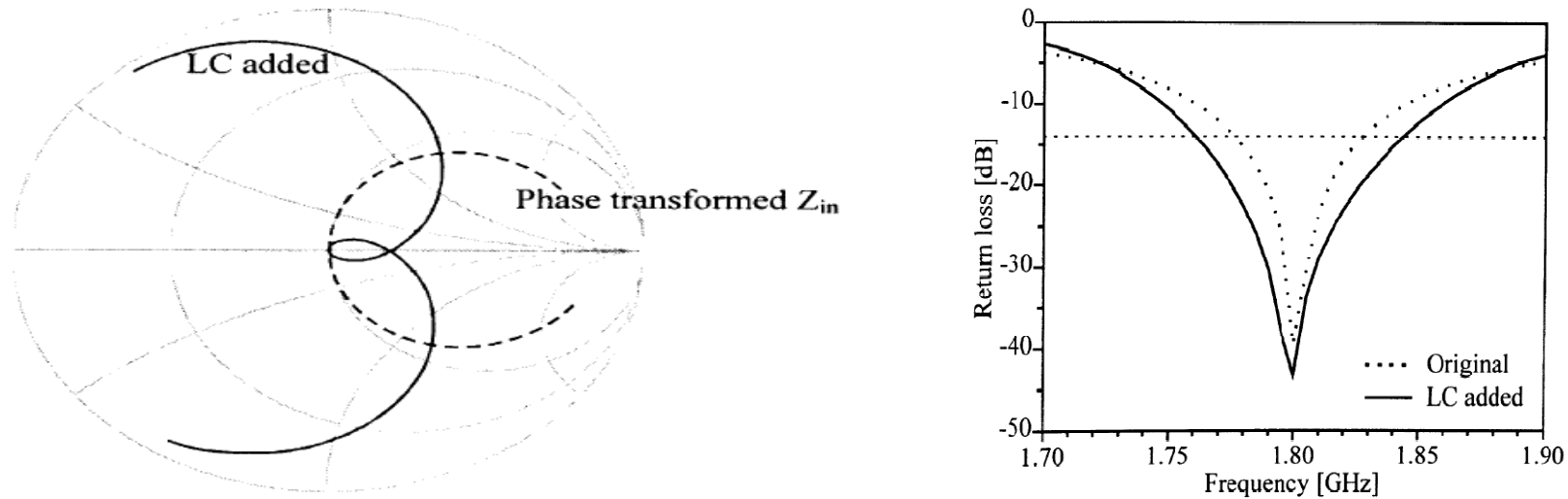

d) Transformation of the real impedance

In **this literature** with an addition of a extra quarter-wave a better matching result is obtained.

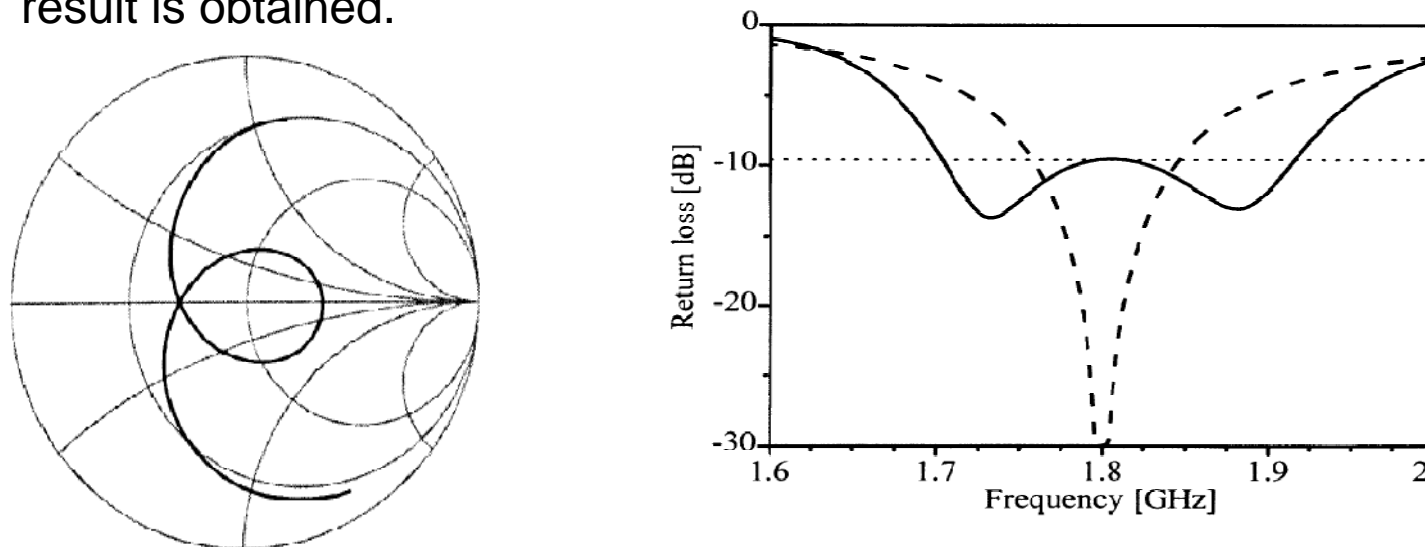

4. Investigation of new matching circuit

4.1 The theory of the new matching circuit

The patch antenna is represented by an equivalent resonant of parallel type. The transmission resonator whose **center frequency** is controlled by I_2 and whose **bandwidth** depends on the size of C_1 and C_2 . If centre frequency and bandwidth are matched to the patch resonator characteristics, and the spacing I_1 is chosen such that the patch equivalent resonator is transformed into the **dual type** with regard to the transmission resonator the combination produces double tuning which can improve bandwidth.

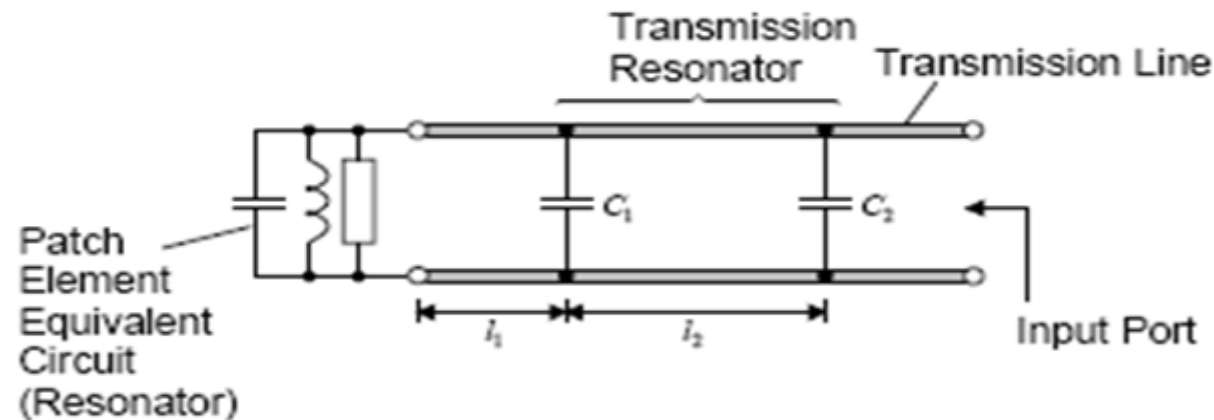

4.2 Design procedure of this matching circuit

4.2.1 Phase transformed patch antenna

In 2.3 we already have the patch antenna.
And with connection of an extra transmission line
($W=2.408\text{mm}$, $L=1.53\text{mm}$) . And the simulation
result is shown below.

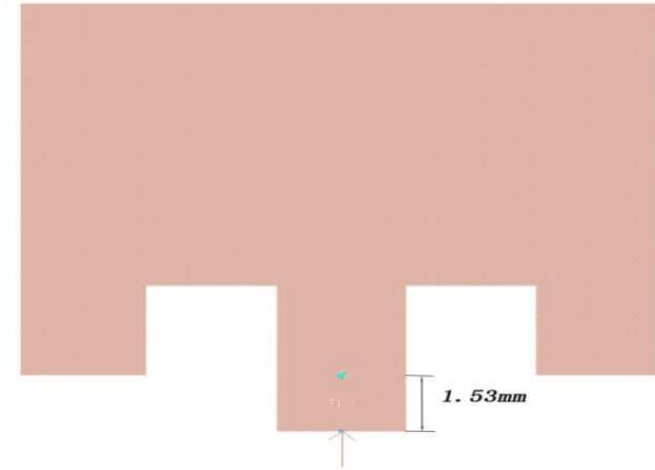

It is clear to see, the impedance of the phase transformed patch antenna has a capacitive component at low frequency (m3) and inductive component at high frequency (m2)

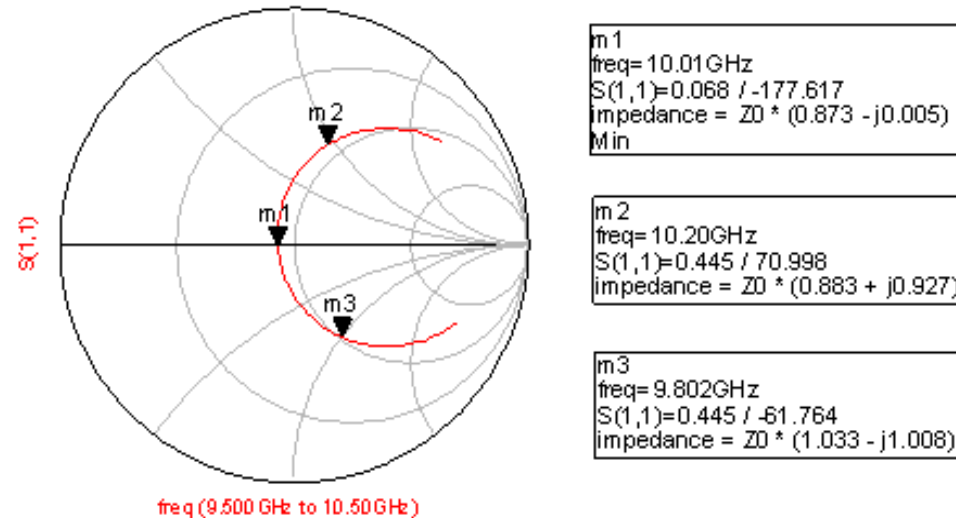

4.2.2 Matching circuit design

a) Using the circuit in 4.1 we draw it in ADS Schematic, we have

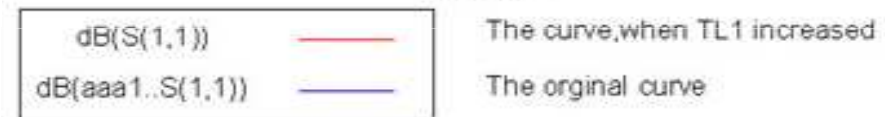
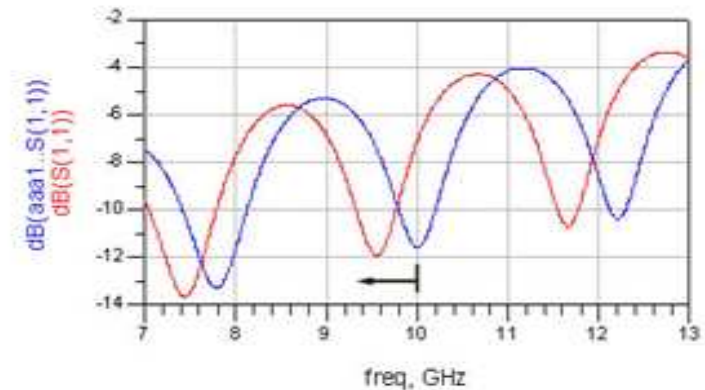
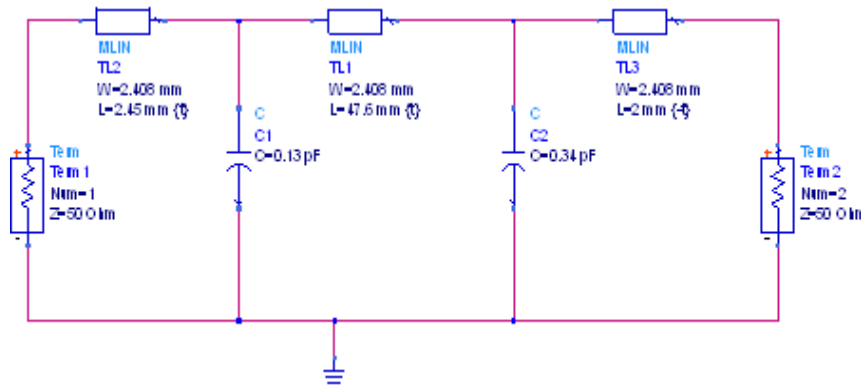

When TL1 is creased, we have the simulation result here.

Increasing (decreasing) TL1, the curve moves to the left (right) and the center frequency (valley) of a certain frequency range is changed. This means the center frequency is controlled by TL1.

When the increased length $\Delta TL1 = n\lambda/2$ ($n=1, 2, 3, \dots$), we can have the minimum value (valley) at the same frequency (here 10GHz). This means with a period of $\lambda/2$, we can always have the minimum reflection factor at the same frequency.

b) Increasing the length TL2 from 1mm to 2.45mm, we have the simulation result here.

Increasing the TL2 the curve moves clockwise. Changing TL2 bring a phase transformation of the matching circuit.

With TL2=2.45, the impedance of the resonator is capacitive at high and inductive at low frequencies. (symmetric about the real axis)

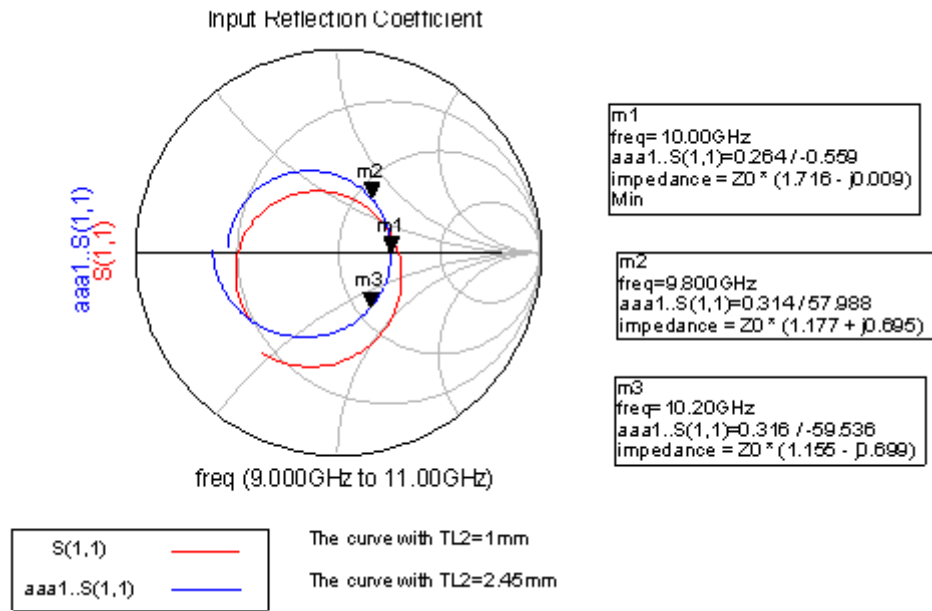

c) From the theory of transmission line, an open-circuited short transmission line (open stub) can be used as capacitance. A new circuit is obtained.

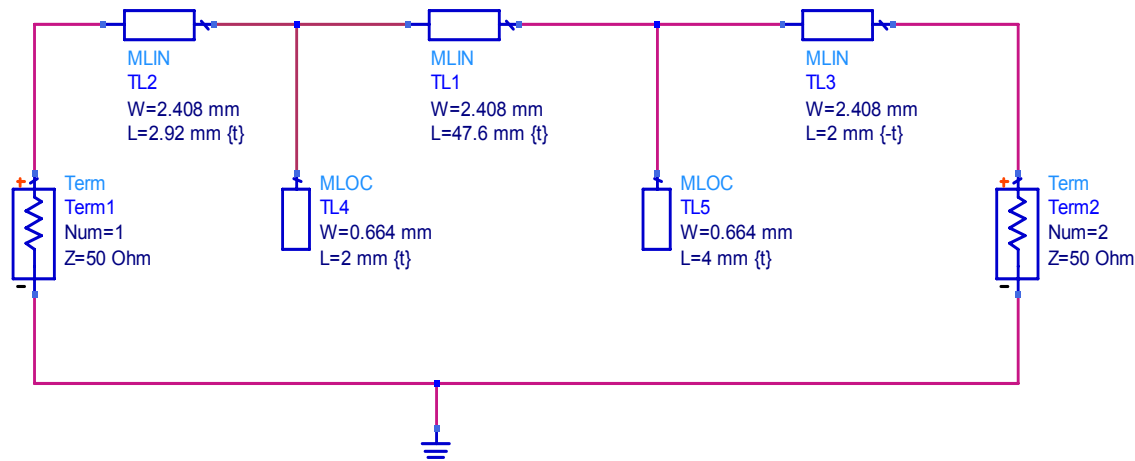
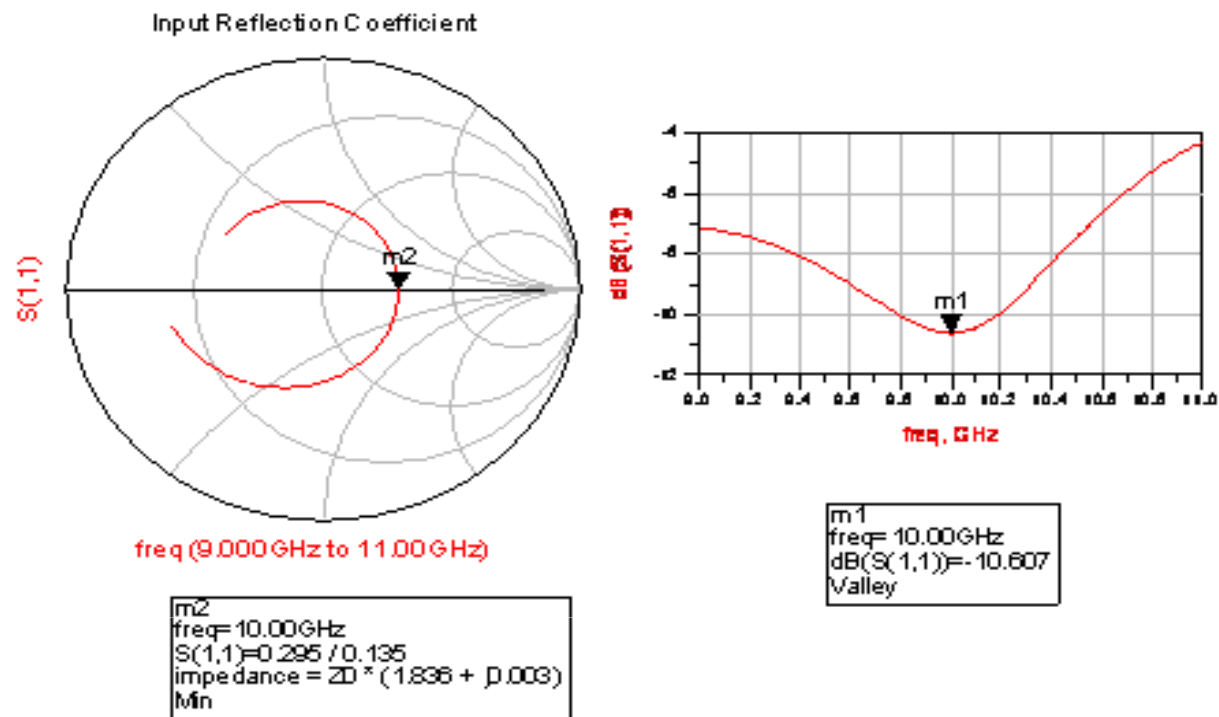
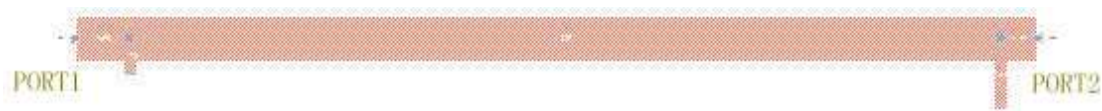

Figure (a)

And the simulation result of Figure (a) is shown here.



d) In ADS schematic, using menu: Layout---Generate or update Layout, we can transform schematic Figure (a) into Layout as shown below.



4.2.3 Phase transformed patch antenna with matching circuit

Connect the phase transformed patch antenna with matching circuit, we have



And we have the simulation result in ADS Momentum here.

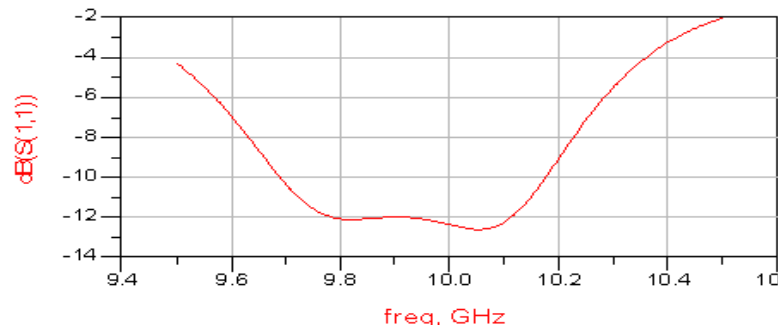

Slightly decrease TL2 in Figure (a) better matching result is obtained.

The bandwidth (-10dB) BW=492MHz, compare to the antenna without matching circuit BW=256M, it is about 92% bandwidth improvement.

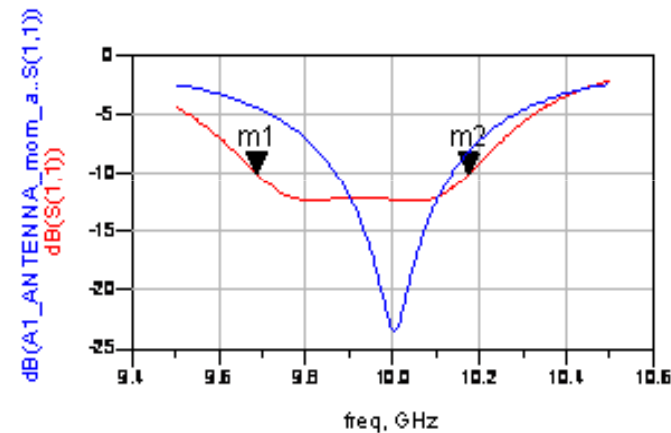

m2
freq=10.18GHz
dB(S(1,1))=-10.012

m1
freq=9.688GHz
dB(S(1,1))=-10.000

4.3 Comparison of the matching result with different TL1 (in Figure (a))

When $TL1 \approx (0.5+n)\lambda/2$ ($n=1, 2, 3, \dots$) the resonant frequency is always at 10 GHz.

A compare of $TL1=47.62\text{mm}$ and $TL1=58.53\text{mm}$ is done, and the result is shown here.

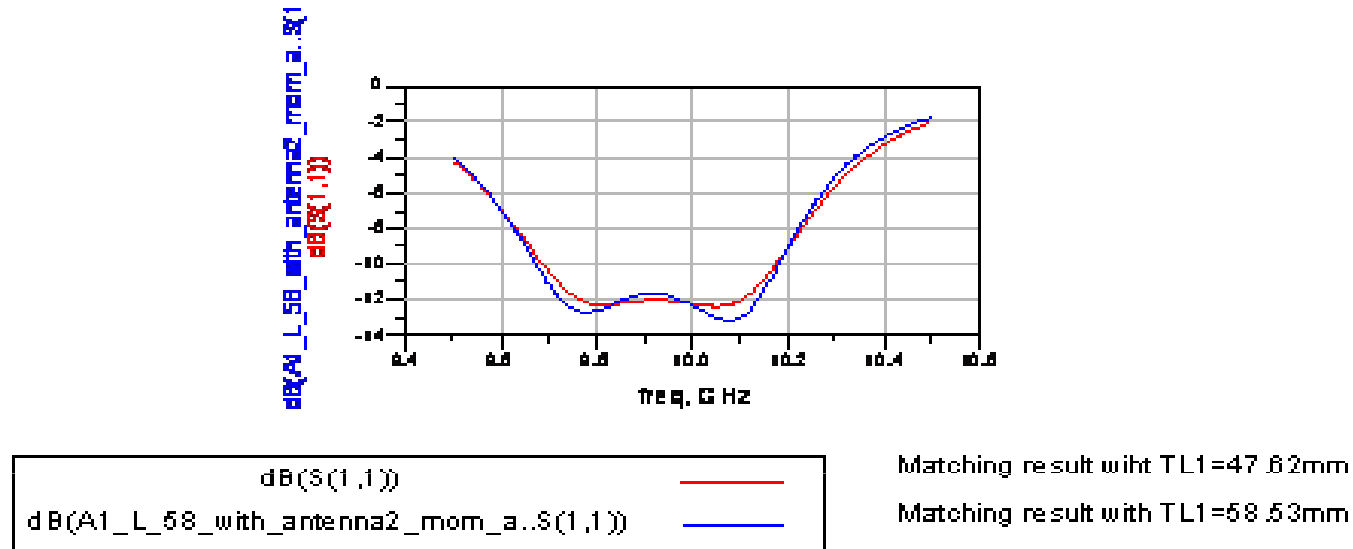

Here it is to see, when $TL1$ is increased from 47.62mm to 58.53mm, the curve of the center frequency goes up and two valleys go down. And the bandwidth is a little increased from 492 MHz to 506 MHz. But it does not mean, increasing $TL1$ can always get the better bandwidth. The bandwidths of different $TL1$ are shown below.

TL1 (mm)	25.66	36.67	47.62	58.53	69.42	80.30	91.92
BW (MH)	369	439	492	506	508	499	492

4.4 Comparison of the matching result with different TL5 (in Figure (a))

In Figure (a) we find out, decreasing TL4 or increasing TL5 has the same effect in simulation. Here just increasing TL5 will be discussed. A comparison with TL5=4mm and TL5=4.4mm was done and the simulation result was shown below.

When TL5 is increased from 4mm to 4.4mm, the curve of the center frequency goes up, more close to -10 dB. And the bandwidth (at -10 dB) is increased from 492 MHz to 575 MHz.

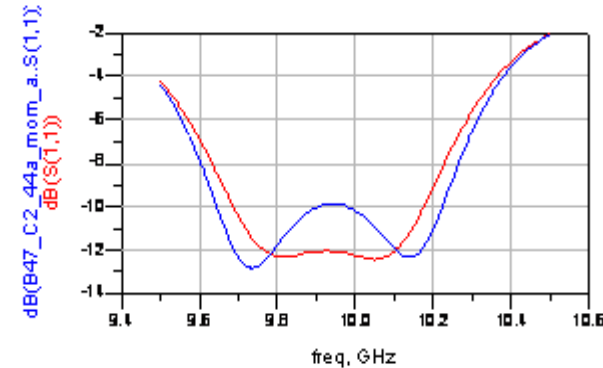

And some other bandwidths (BW) with different TL5 are also simulated as shown below.

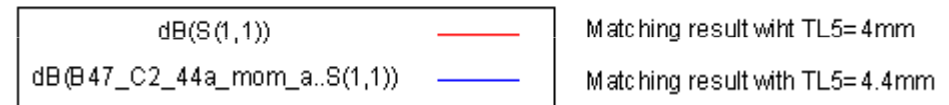

When we increase the “capacitance” TL5 we can get a better bandwidth, but at the same time the return loss in middle goes up and in design it should not go up about -10 dB.

TL5 (mm)	4.0	4.1	4.2	4.3	4.4
BW (MH)	492	510	532	554	575

5. Broadband matching of patch-array antenna

5.1 The theory of the patch array antenna feed network

The concept of transmission resonator matching in 4.1 can be translated from a single element antenna to a multi-element antenna, given that the feed network is of the symmetrical corporate type and that all elements are connected to the central feed port via equal length to provide uniform phase distribution. An applicable network is given in the Literature as shown below.

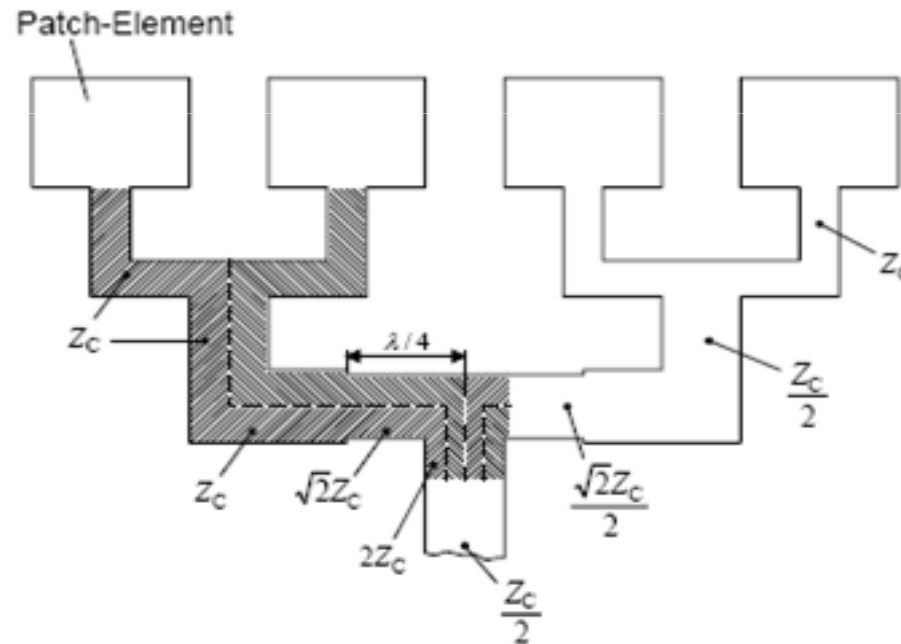

5.2 Design procedure of the patch array antenna feed network

a) The substrate material is changed to NELTEC 9233 with

$$\epsilon_r=2.33, h=0.79\text{mm}(35\mu\text{m Cooper}), \tan\delta=0.0011$$

So the new dimension of the patch antenna was calculated. And we have $W=11.62\text{mm}$, $L=9.95\text{mm}$, $w_f=2.32\text{mm}$. Similarly with a microstrip line $W=2.32$, $L=1.8\text{mm}$, the phase of the patch antenna was transformed as shown below.

b) T-Junction design

The T-Junction is shown below, With $L=\lambda/4$ and character resistance $\sqrt{2}Z_0$, transforming character resistance Z_0 to $2Z_0$. And when two side of $2Z_0$ parallel in the middle point, the character resistance is again Z_0 .

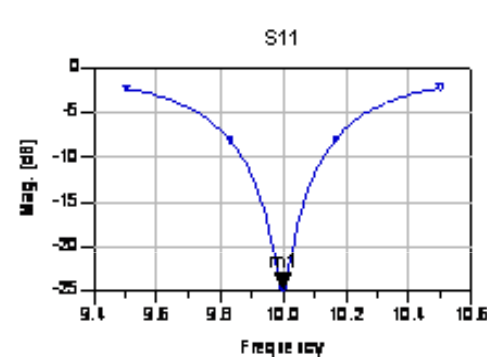

```
m1
freq=10.00GHz
dB(antenna_with_L2_mom_a..S(1,1))=-24.800
Min
```

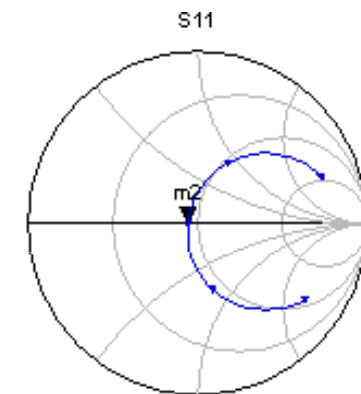

```
m2
freq=10.00GHz
antenna_with_L2_mom..S(1,1)=0.058 / 171.962
impedance= Z0 * (0.892 + j0.014)
Min
```

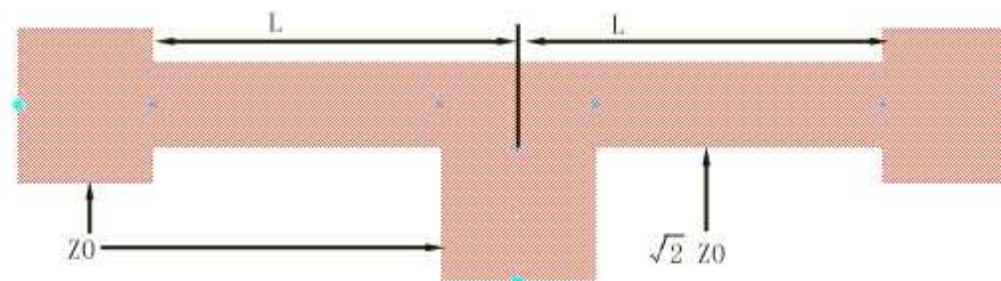

c) Feed network design in Layout

Let the distance between antennas be $\lambda_0/2=15\text{mm}$ We have the dimension of the network as shown Figure (b)

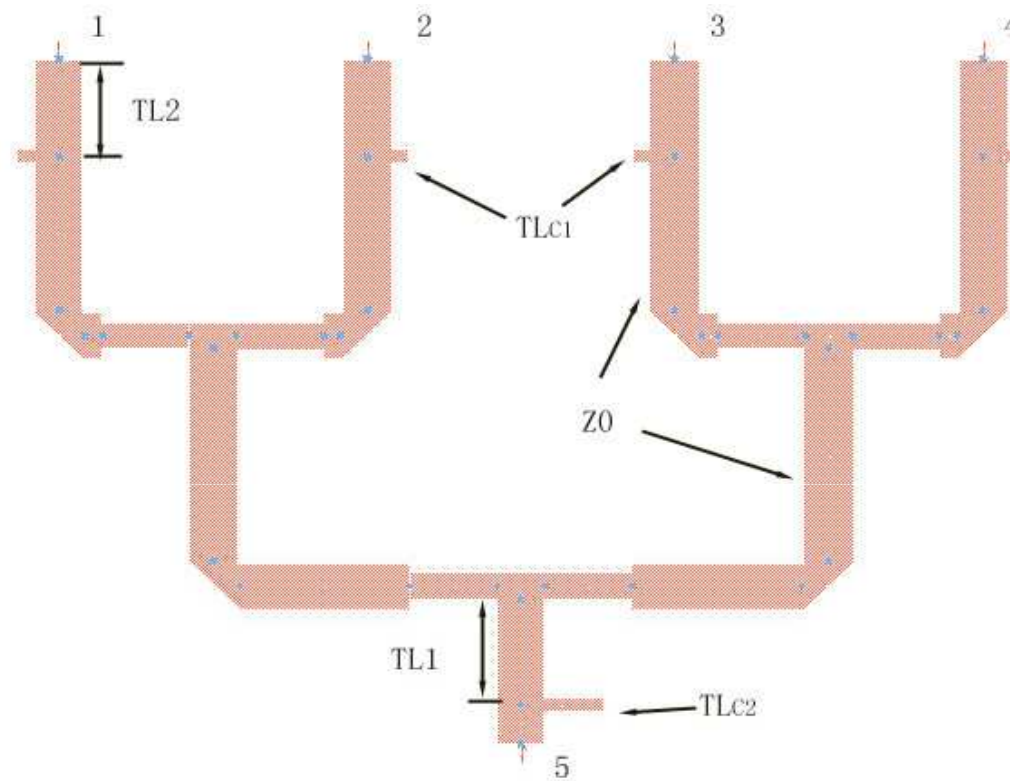

Figure (b)

Here the length of TL1, TL2, TL_{C1} and TL_{C2} are not confirmed. Later we can optimize the network via change of these parameters. Here it must be kept in mind that, when we change a TL2 or L_{C1} in a port, all 4 ports must be changed the same way at the same time.

d) Optimization of the feed network in ADS Schematic

We can translate the Layout (Figure (b)) into Schematic in ADS Layout using the menu: Schematic --- Generate or update schematic. In ADS schematic it is easily the network to be simulated and optimized.

Because of the symmetry of the network all ports (1, 2, 3 and 4) have the same result. So only port 1 was considered. Changing the length TL1 we can change the resonant frequency of the network at port 1. And changing TL2 we can rotate the impedance locus at port 1. And with $TL_1=5.44$ mm, $TL_2=3$ mm, $TL_{C_1}=2$ mm, $TL_{C_2}=4$ mm, we have the simulation result of port 1 as shown below.

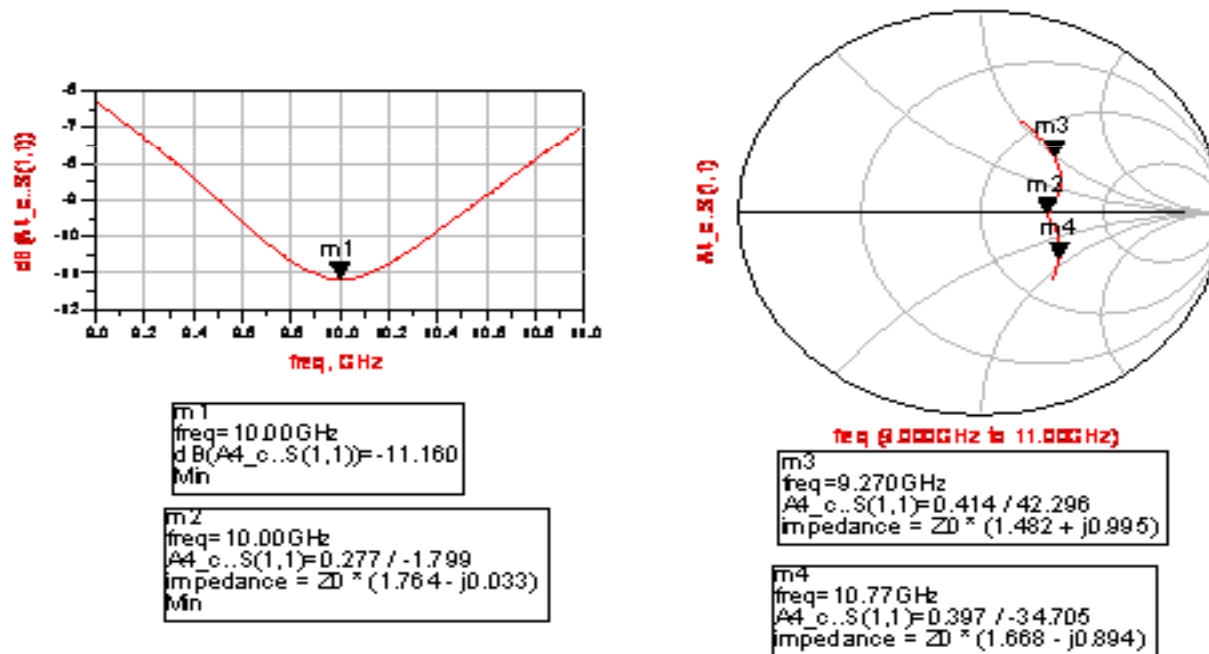

e) Simulation of the network with array antennas in ADS Momentum.

Now we connect all 4 ports with phase transformed antennas and simulate in ADS Momentum, the simulation results are shown here.

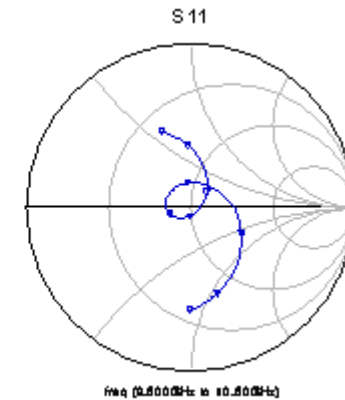
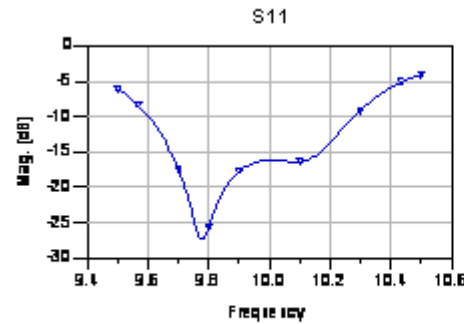
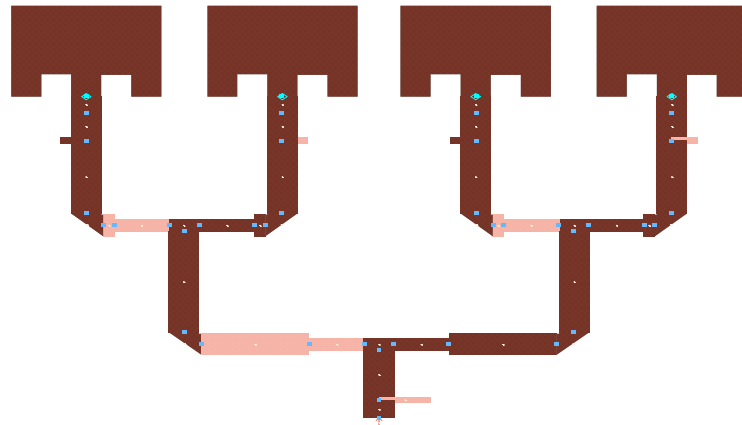

Then we increase TL2 (Figure (b)) to 3.3mm, we have a better result as shown here

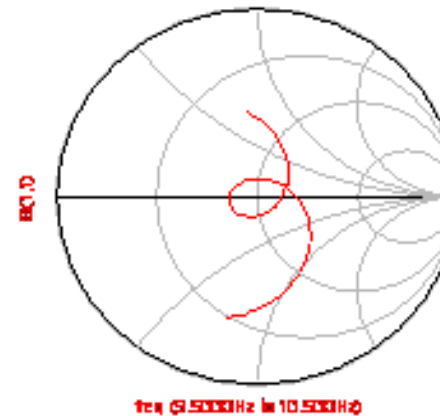
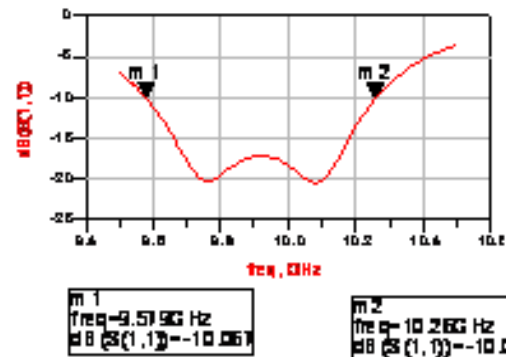

5.3 Comparison of the matching network with different TL_{C2} (in Figure (b))

We compared $TL_{C2}=4\text{mm}$ and $TL_{C2}=4.8\text{mm}$ and the simulation result is shown below

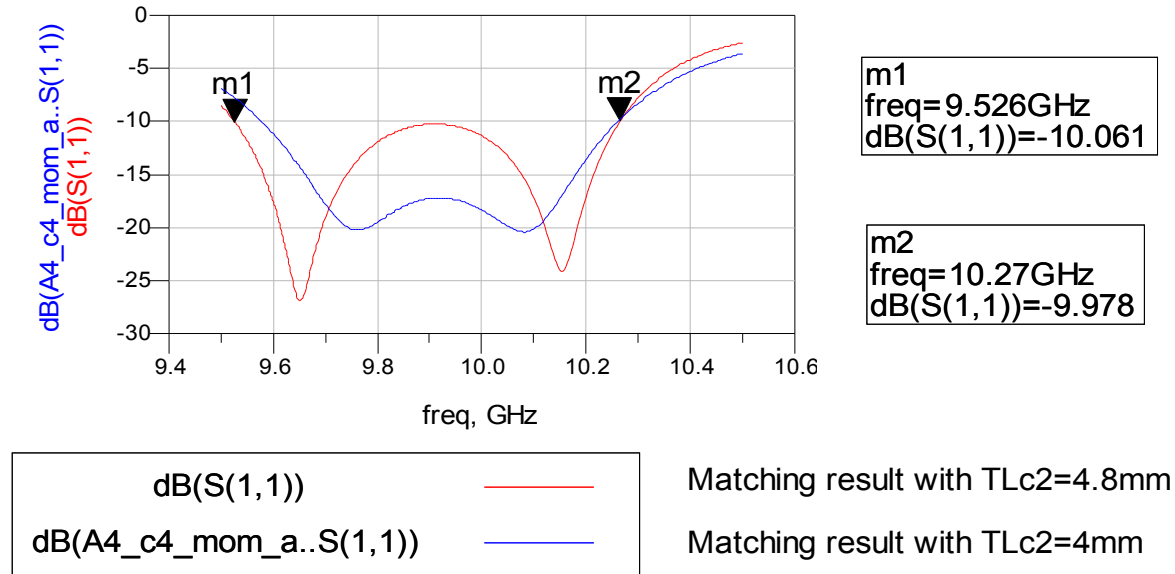

Here is clear to see for $TL_{C2}=4.8\text{mm}$ we have better bandwidth $BW=744\text{MHz}$ and at the center frequency it is more close to the -10dB .

5.4 Comparison of the antenna array with or without resonant matching

When all open stubs were removed from the matching circuit, we have the Layout,

And we have simulation result below

Here we have the bandwidth (at -10dB) of the antenna array without open stubs BW=422 MHz.

For $TL_{C2}=4.8\text{mm}$ we have the bandwidth of antenna array with matching circuit BW=744MHz. This about 76.3% bandwidth improvement.

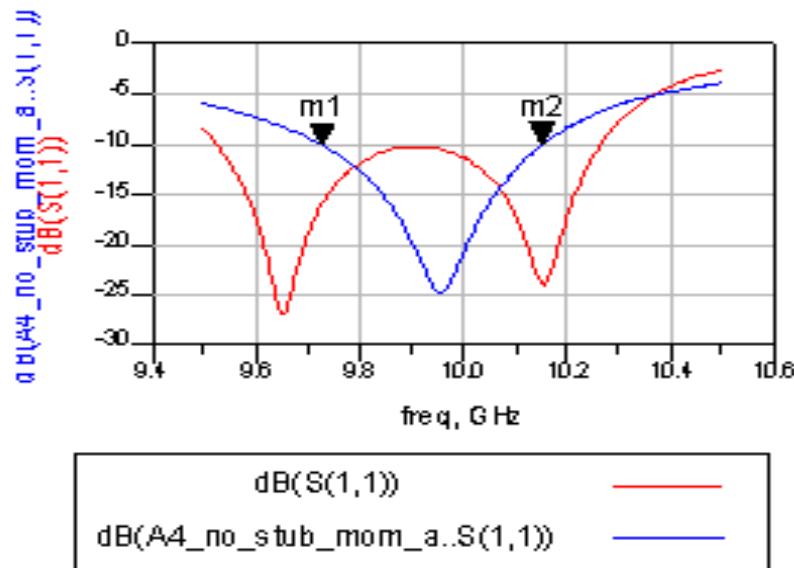
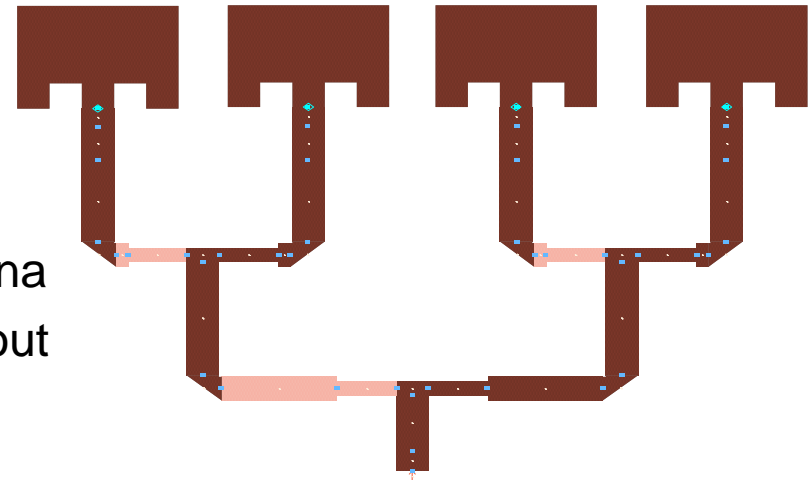

m1
freq=9.728GHz
dB(A4_no_stub_mom_a..S(1,1))=-10.055

m2
freq= 10.15GHz
dB(A4_no_stub_mom_a..S(1,1))=-10.008

Antenna arraywith matching circuit

Antenna arraywihtout matching circuit

5.5 Manufacture of the Matching network with array antennas

In 5.2 we have designed the feed network with antennas ($TL_{C2}=4.8\text{mm}$).

Now we define the cut line of the circuit board, as shown below

Then we export this design as Gerber file. And we send the File cond.gbr to the factory to produce the circuit board.

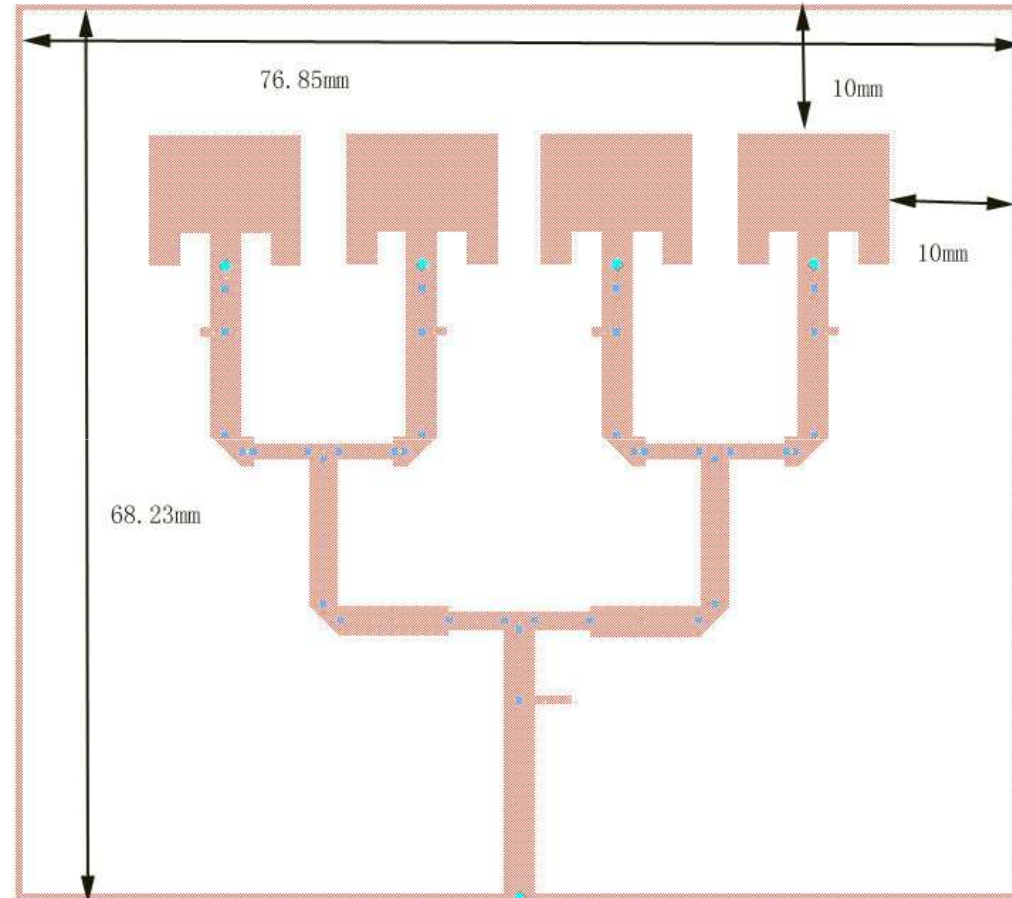

And the finished board with SMA component is shown here

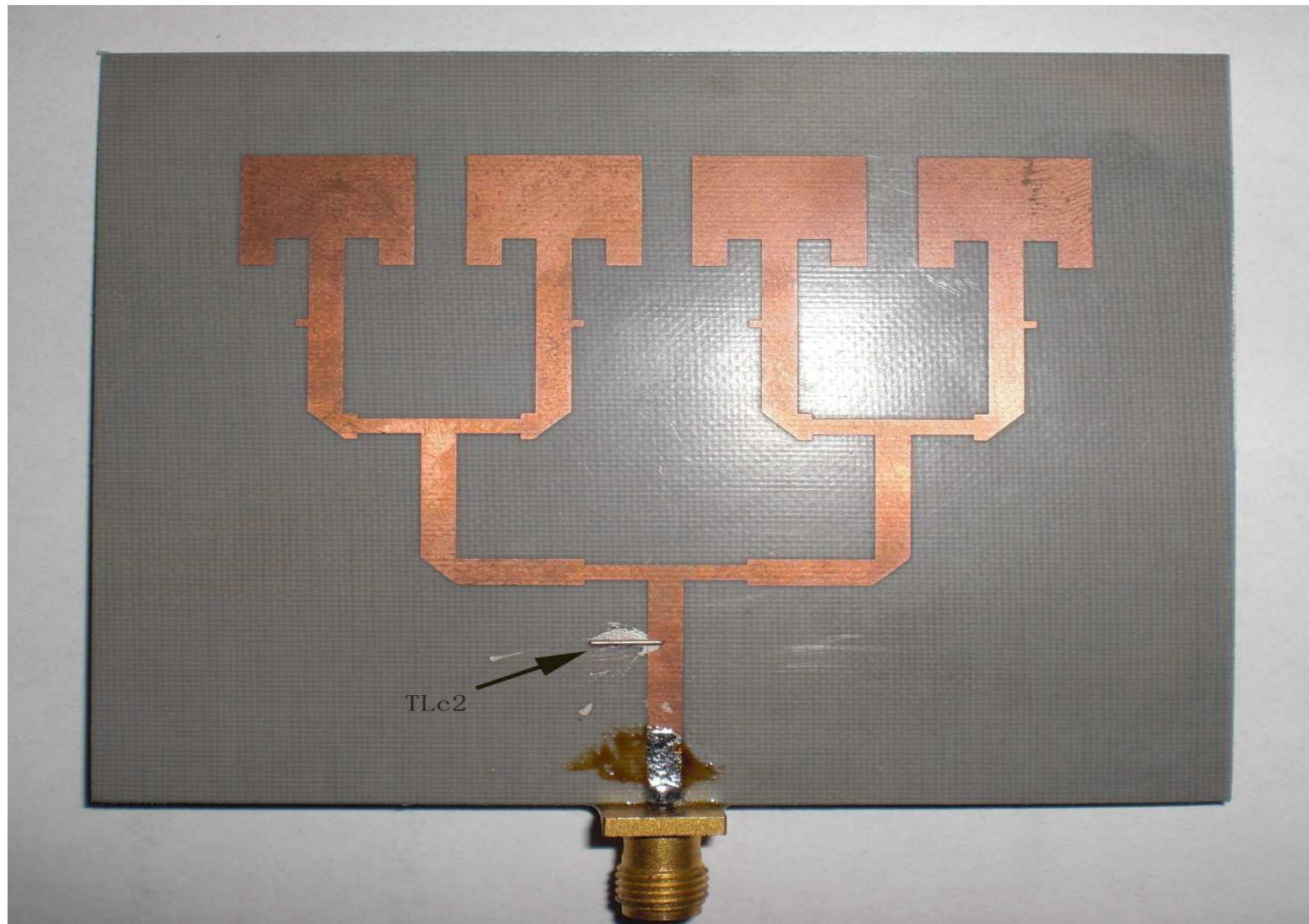

5.6 Test of the matching network

5.6.1 Bandwidth test

We connect the board with the test equipment. In ADS Schematic using Menu: Tools---Instrument Server, we can show the test result in ADS Data Display. We have the test result as shown here.

Here we can see the curve of the test result is not dual-resonant like the simulation result.

So we try to increase the capacitance “ TL_{C2} ” pasting an extra conductor on the capacitance “ TL_{C2} ”. And a better result is obtained.

And the bandwidth is now $BW=790$ MHz. In simulation we have the antenna array bandwidth $BW=744$ MHz. The test result $BW=790$ MHz compared to antenna without matching in simulation (422MHz), this is a bandwidth improvement 368 MHz (improvement factor 87.2%).

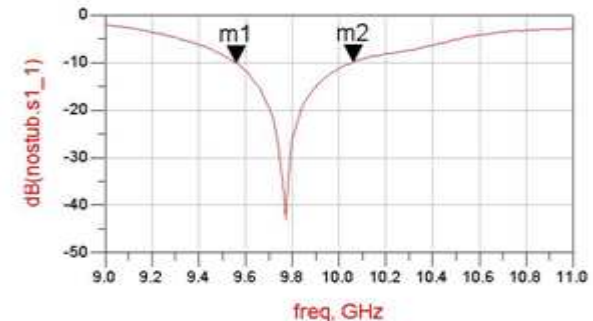

m1
freq=9.560GHz
dB(nostub.s1_1)=-10.131

m2
freq=10.06GHz
dB(nostub.s1_1)=-9.959

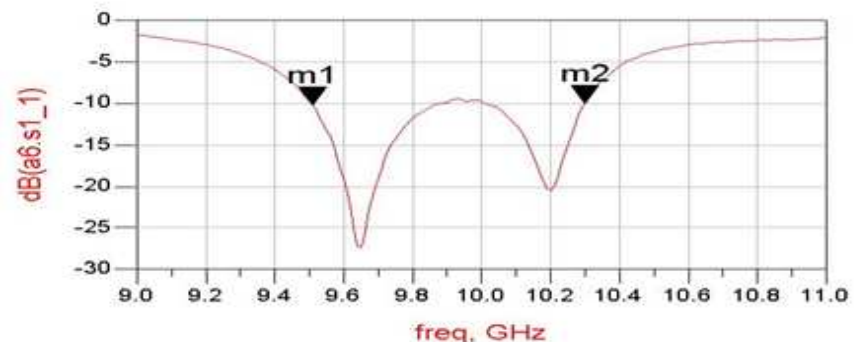

m1
freq=9.510GHz
dB(a6.s1_1)=-10.247

m2
freq=10.30GHz
dB(a6.s1_1)=-10.022

5.6.2 Radiation pattern test

- a) Three frequency points (9.9 GHz, 9.7GHz and 10.1GHz) were measured. The test results are shown below.
- b) Using ADS Momentum---Post Processing---Radiation Pattern control, we can have the Radiation Pattern of the antenna system in simulation
- c) Compare the simulation results of antenna array with and without feed network, it is clear to see, the zero points of the second Side Lobe in antenna array without feed network are more deeper than in antenna array with feed network
- d) From test results and simulation results with matching circuit, we can calculate the Side Lobe (SL) Distance of the first side lobe. Here both the left (L) and the right (R) side lobes are calculated.

	9.9GHz		9.7GHz		10.1GHz	
	L	R	L	R	L	R
SL Distance (test)	16.07 dB	14.24 dB	16.91 dB	14.92 dB	12.26 dB	/
SL Distance (simulation)	14.29 dB	14.70 dB	11.80 dB	12.35 dB	14.54 dB	14.13 dB

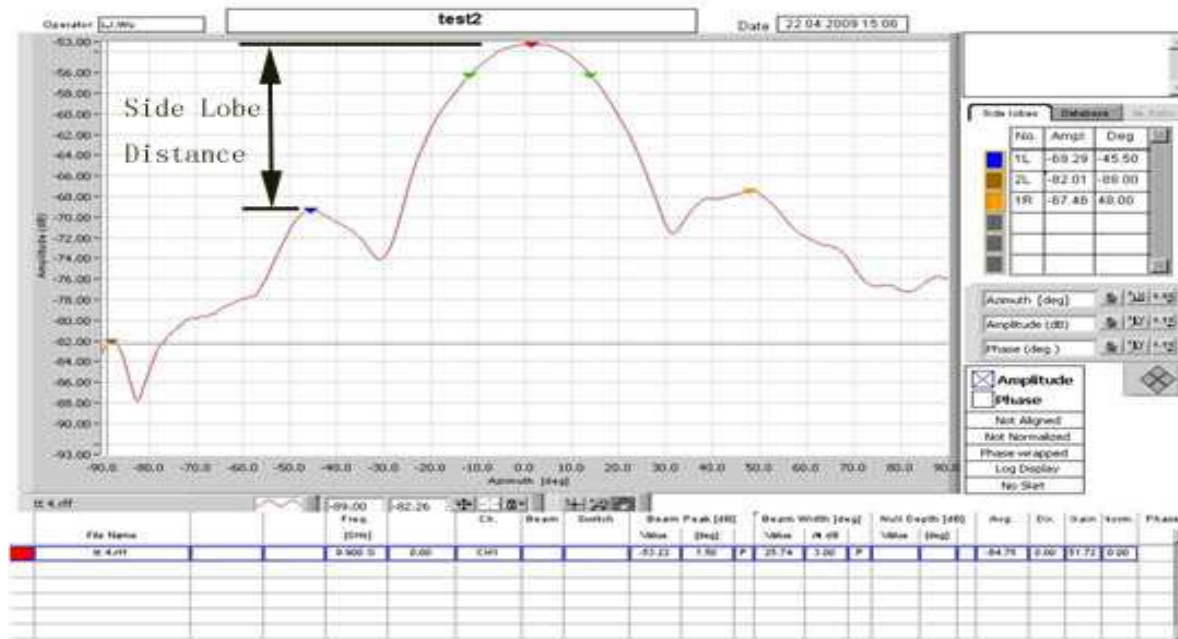

Test result at frequency 9.9 GHz

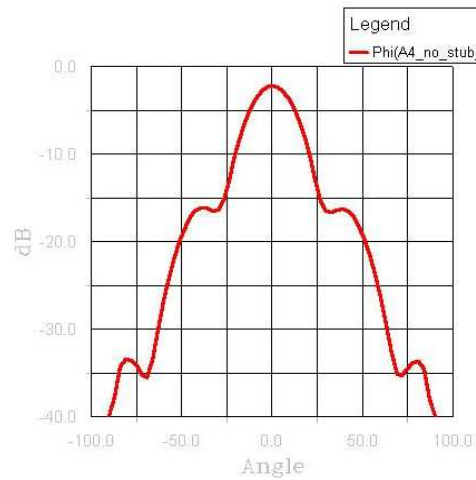

simulation result (without matching network)
at frequency 9.9 GHz

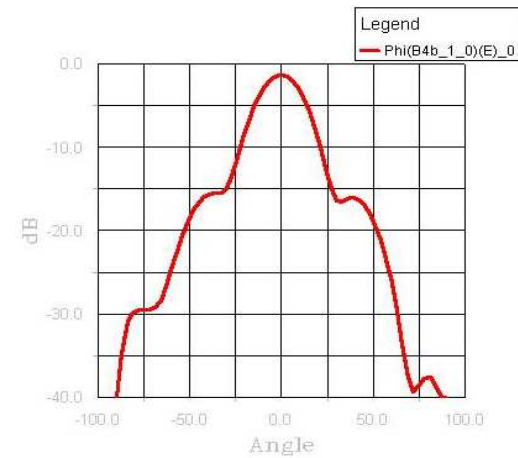

simulation result (with matching network)
at frequency 9.9 GHz



Test result at frequency 9.7 GHz

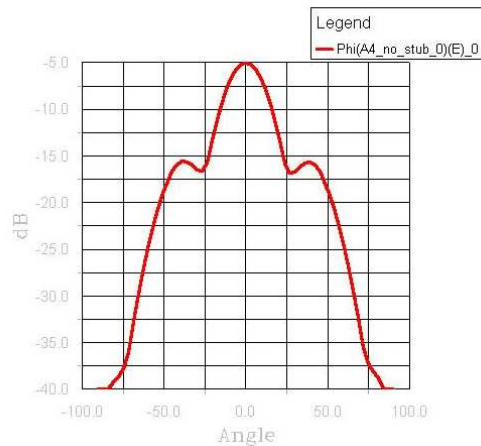

simulation result (without matching network)
at frequency 9.7 GHz

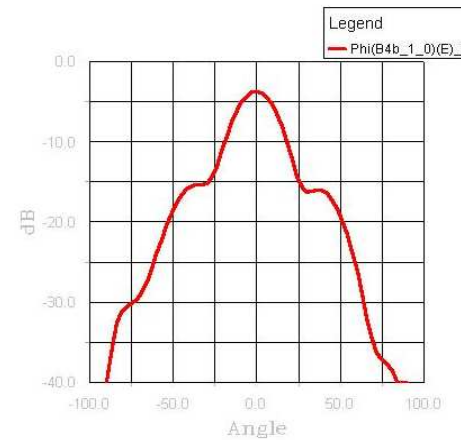

simulation result (with matching network)
at frequency 9.7 GHz

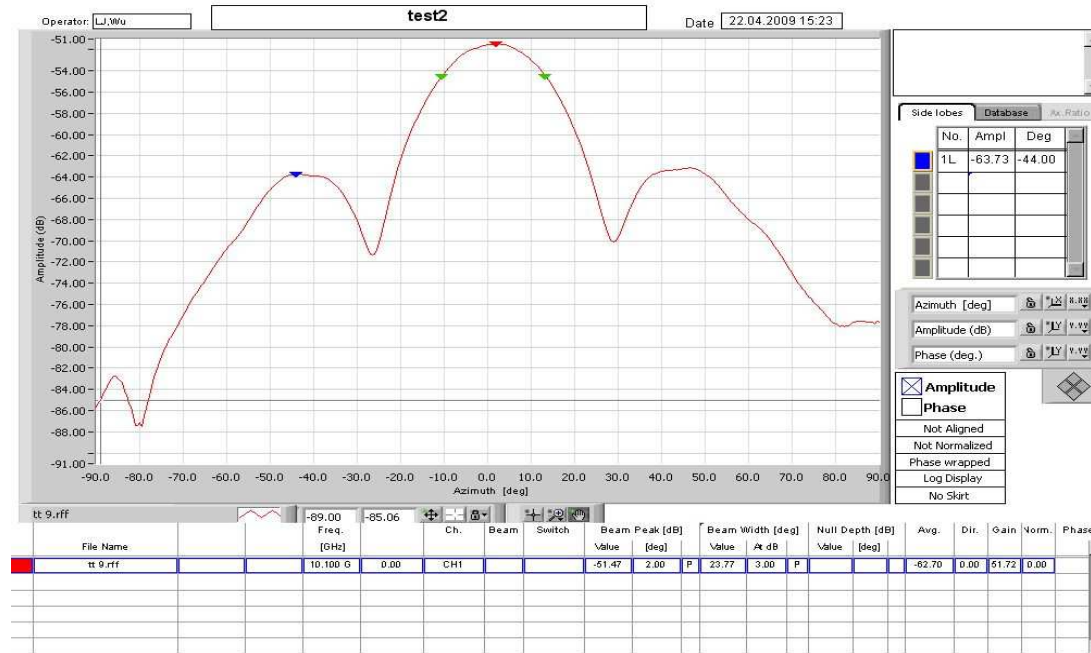

Test result at frequency 10.1 GHz

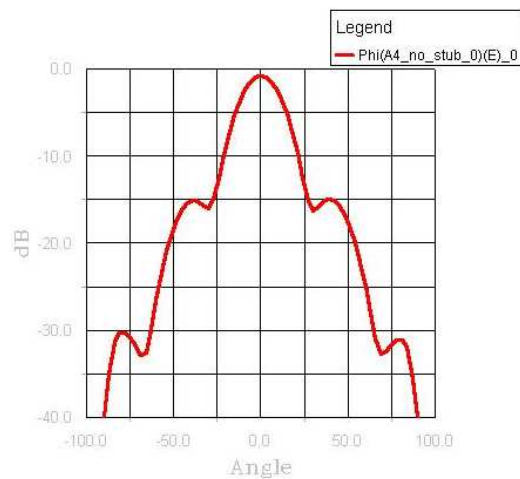

simulation result (without matching network)
at frequency 10.1 GHz

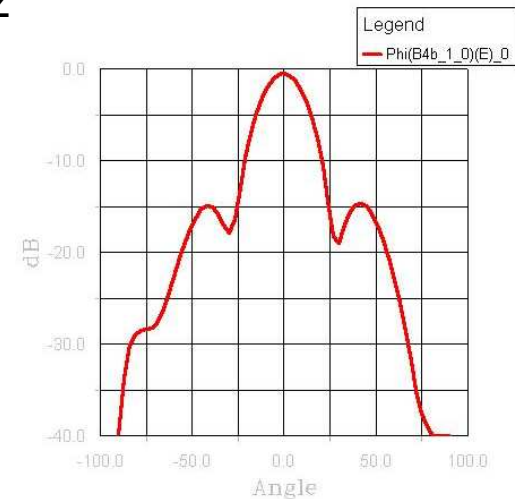

simulation result (with matching network)
at frequency 10.1 GHz

6. Conclusion

The theory of using resonant matching circuit to improve the bandwidth of the patch antenna was proved. A bandwidth (at -10 dB) improvement of the patch antenna from 256 MHz 492 MHz (improvement 92%) was achieved in simulation. With the modification of the matching network more improvement can also be achieved.

And using resonant matching circuit to improve the bandwidth of patch-array antenna can also work very well. A bandwidth improvement for the antenna array from 422 MHz to 744 MHz was achieved (improvement 76.3%) in simulation. And in the test the bandwidth 790 MHz was achieved via modification of the feed-network. That is the bandwidth improvement 87.2%.

Thank you for your attention!