

## Flexible thermally conductive pipes for heat exchanger systems

### Problem

- Polymers generally have a low TC
- Increase in TC through additives such as graphite
- Additives dramatically reduce mechanical flexibility
- Trade-off: Flexibility ↔ Thermal conductivity

### Objective

- Innovative pipe-die for targeted orientation of fillers
- Use of anisotropic compound properties for the most efficient heat conduction possible
- Reduction of the necessary filler input to maintain a high level of flexibility

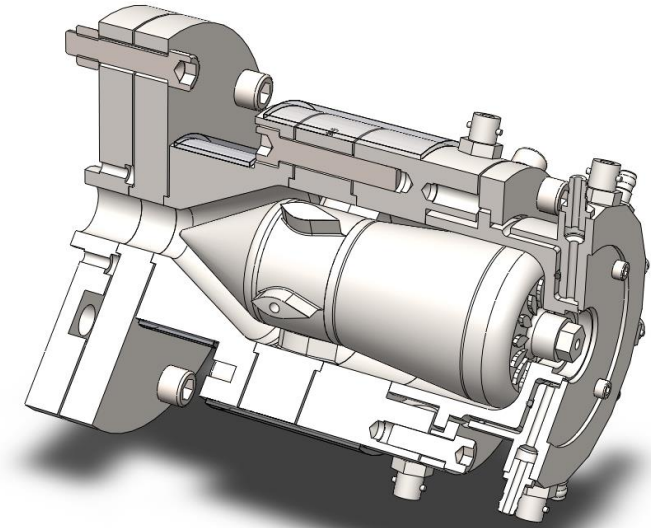

EUROPÄISCHE UNION  
Investition in unsere Zukunft  
Europäischer Fonds  
für regionale Entwicklung

Ministerium für Wirtschaft, Innovation,  
Digitalisierung und Energie  
des Landes Nordrhein-Westfalen



2014 EFRE.NRW  
Investitionen in Wachstum  
und Beschäftigung

Projektzeitraum:  
05/2019 – 10/2022

Förderkennzeichen:  
EFRE-0801478

Ansprechpartner:  
Kevin Buchalik, M. Sc.  
kevin.buchalik@uni-due.de  
0203 379 1732